

CMT SHEET NAME	REF AREA
<i>/sys/cmt_if/prod_test_pattern</i>	2060-2069
<i>/sys/cmt_if/battery_conn</i>	2070-2099
<i>/sys/cmt_if/audio</i>	2000-2029
<i>/sys/cmt_if/audio</i>	2100-2199
<i>/sys/cmt_if/itu</i>	2400-2499
<i>/sys/cmt_if/camera</i>	2500-2599
<i>/sys/cmt_if/sim</i>	2700-2799
<i>/sys/cmt_if/emu_rap</i>	3100-3120
<i>/sys/cmt_if/wing</i>	4000-4099
<i>/sys/cmt_if/lid</i>	3800-3899
<i>/sys/cmt_if/bt</i>	6000-6099
<i>/sys/cmt_if/wlan</i>	6300-6510
<i>/sys/cmt_if/conn/charger-USB</i>	2030-2039

CMT SHEET NAME	REF AREA
<i>/sys/cmt_engine/power/vilma</i>	2200-2299
<i>/sys/cmt_engine/power/betty</i>	2300-2389
<i>/sys/cmt_engine/power/coreps</i>	2390-2399
<i>/sys/cmt_engine/digi/rapido</i>	2800-2849
<i>/sys/cmt_engine/digi/geniomux</i>	2850-2899
<i>/sys/cmt_engine/digi/mem_cmt/combo</i>	3000-3099
<i>/sys/cmt_engine/digi/mem_cmt/mass_memory</i>	3200-3299

RF SHEET NAME	REF AREA
/RF	7500-7599
/MUTANT	8000-8010

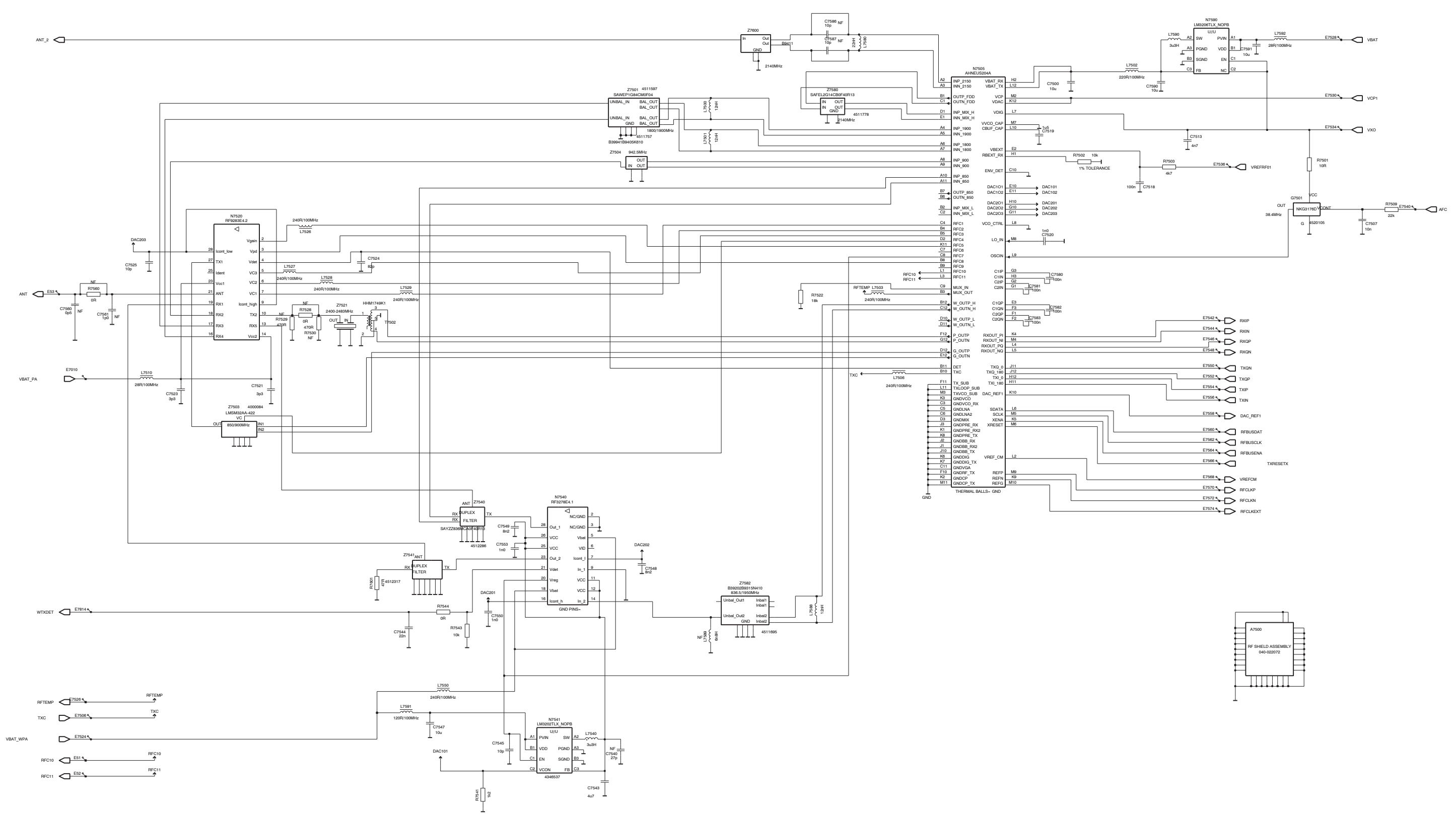

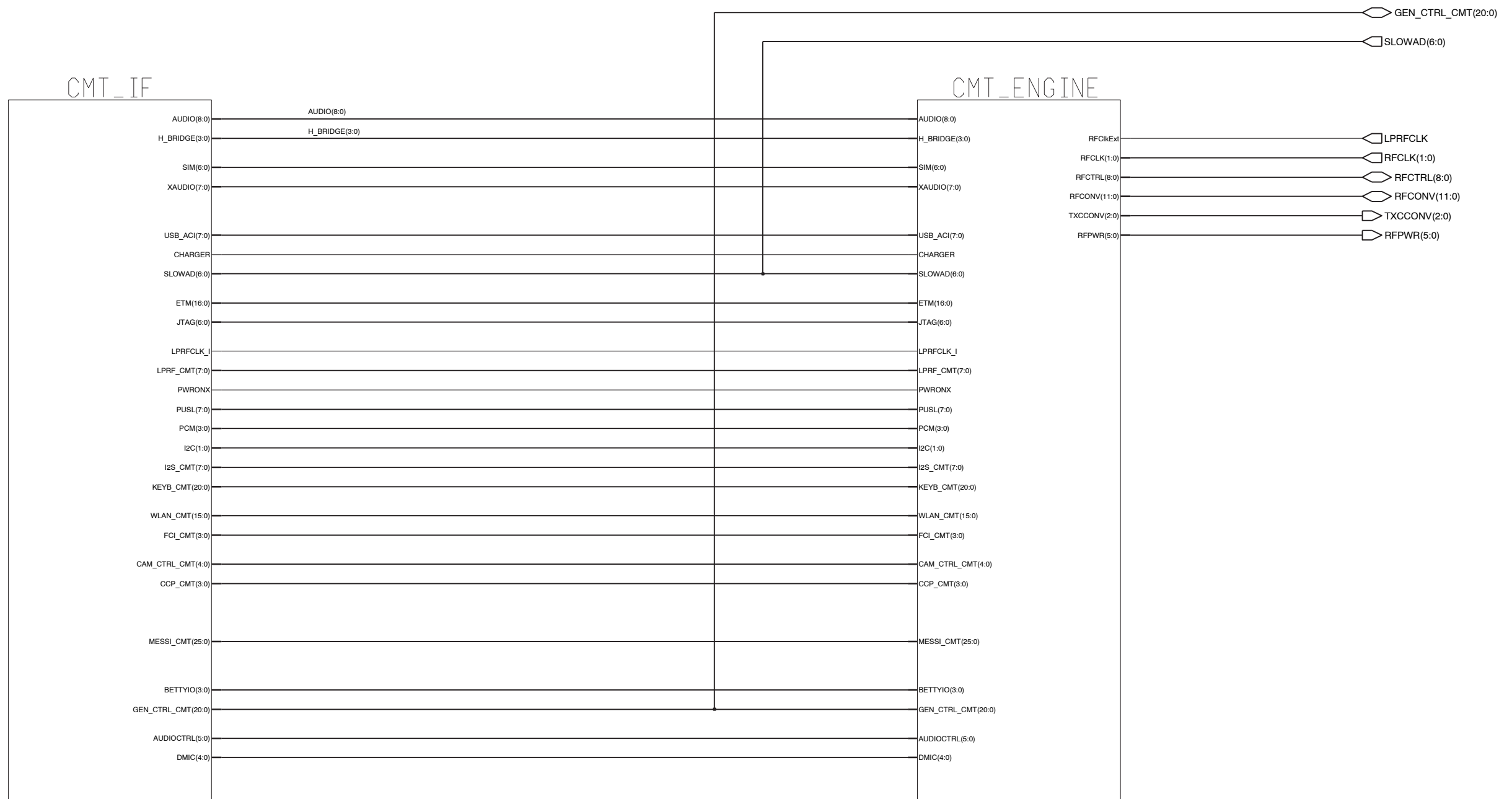

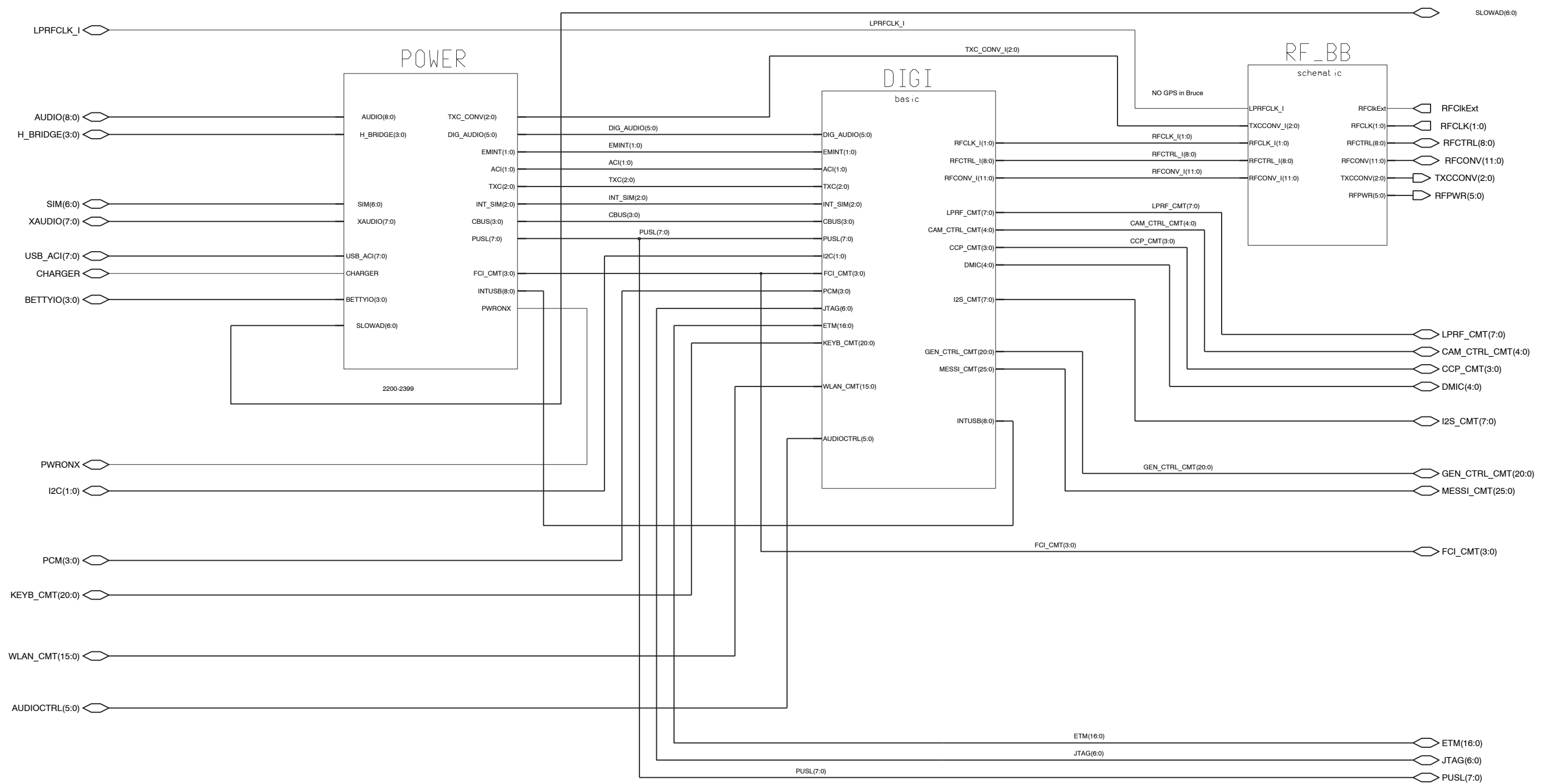

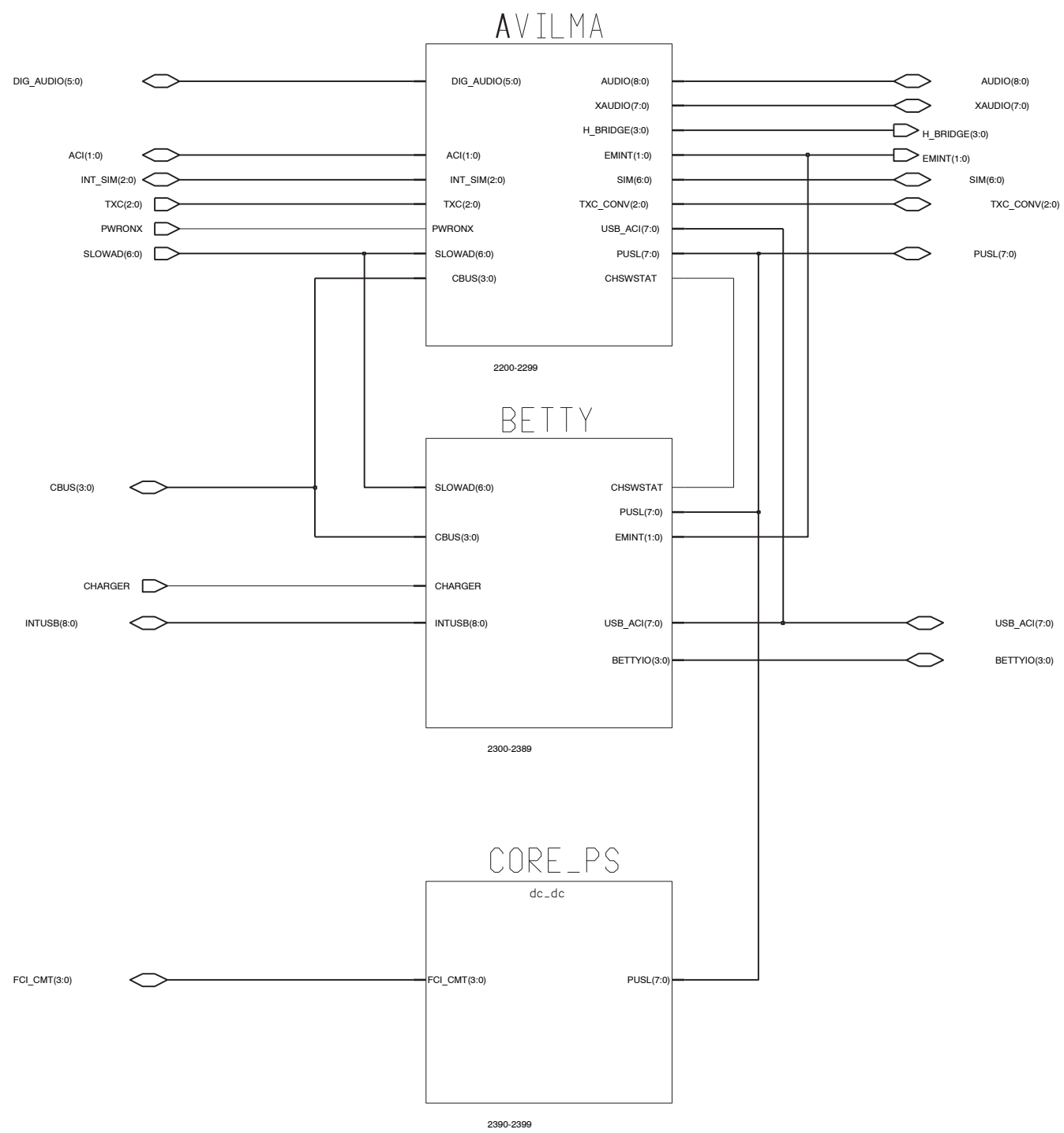

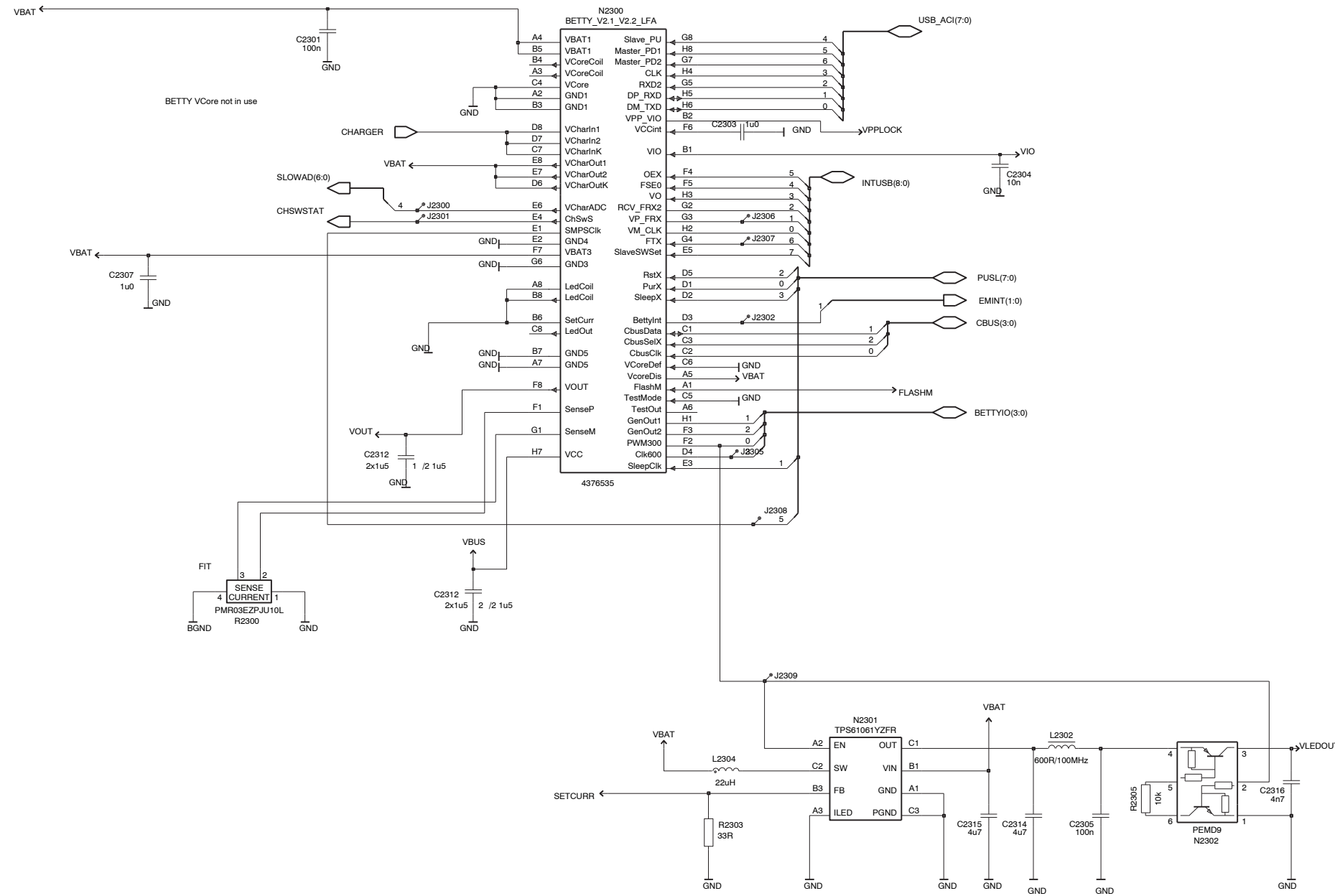

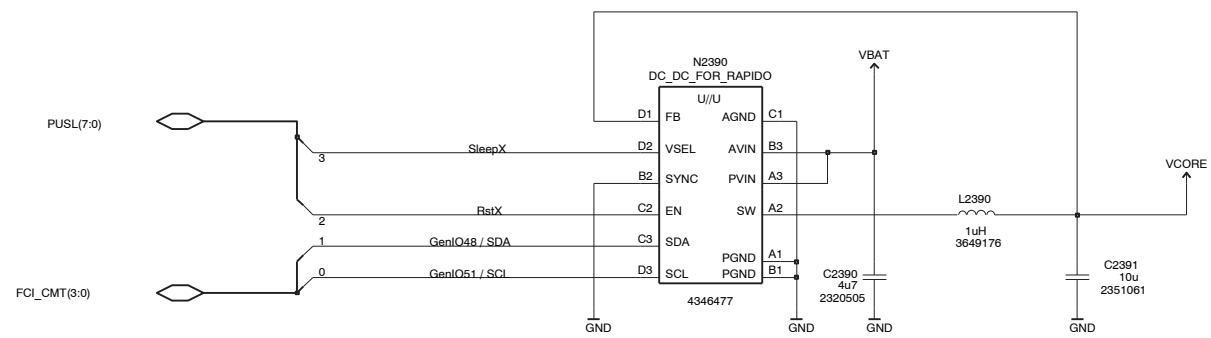

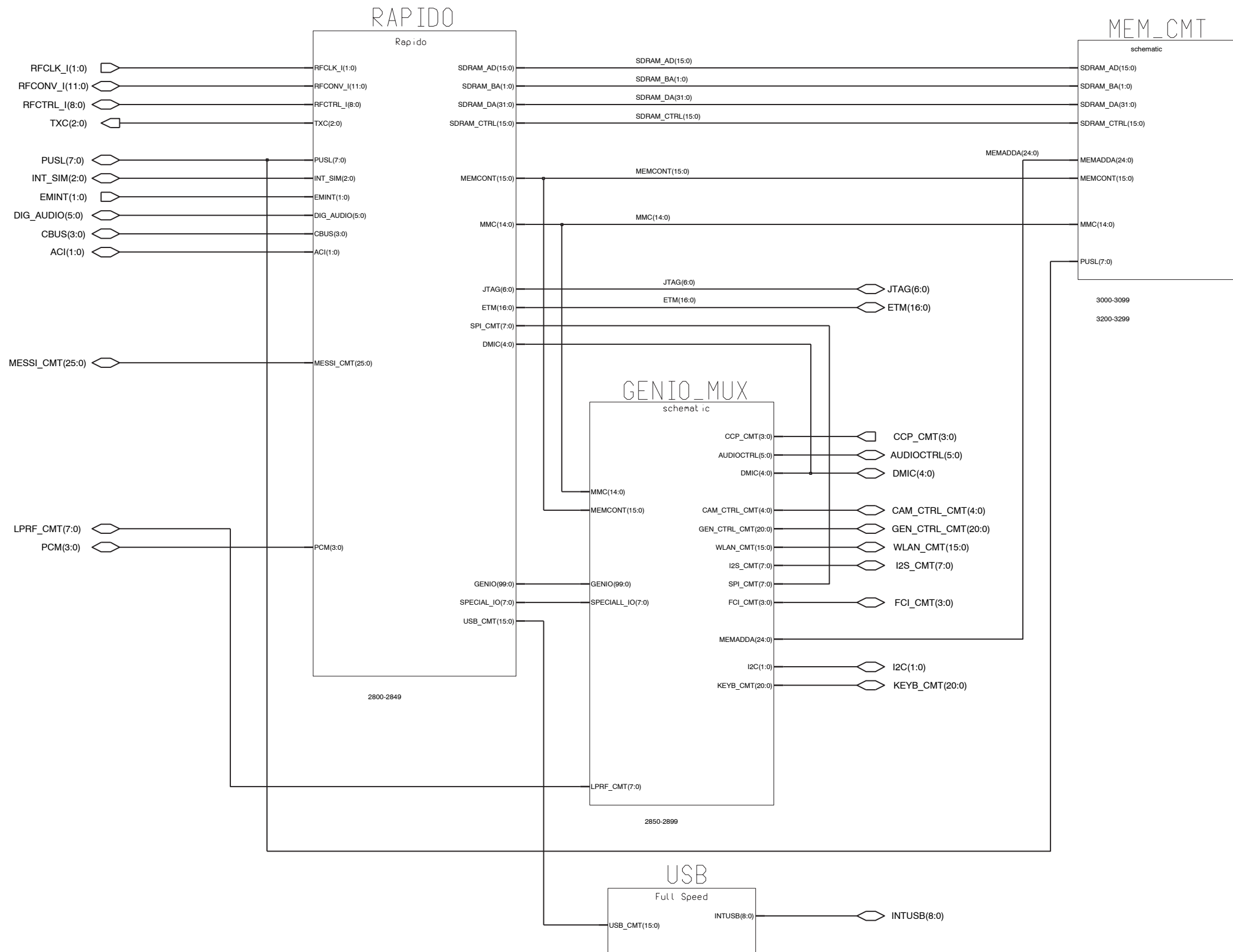

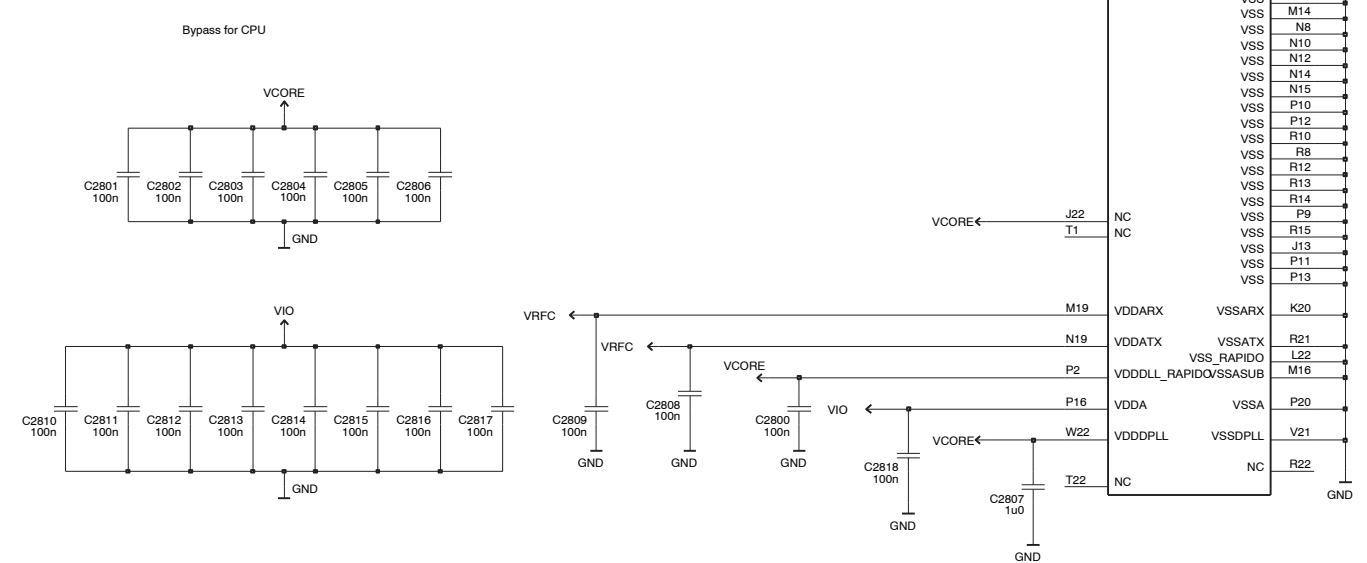
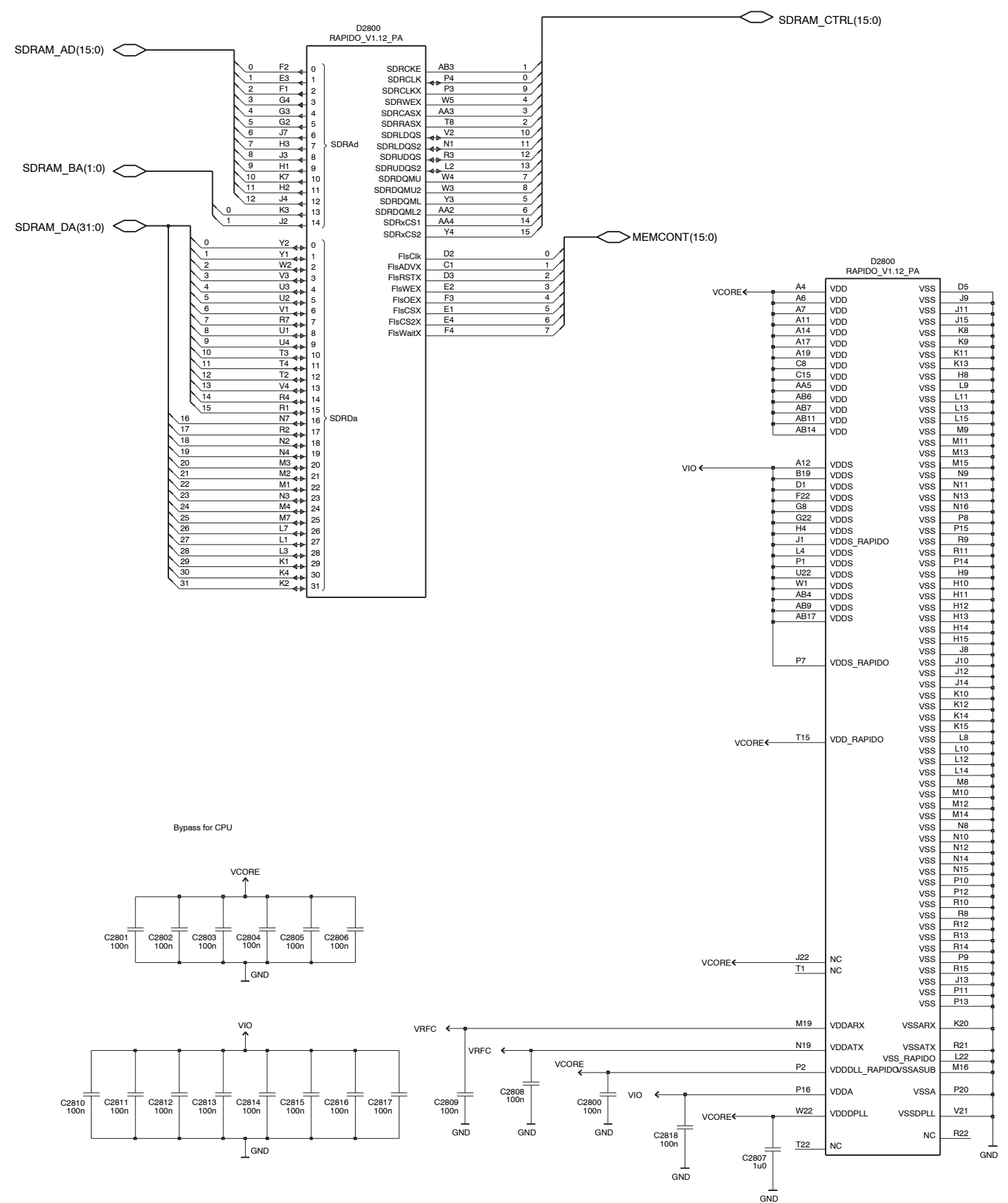
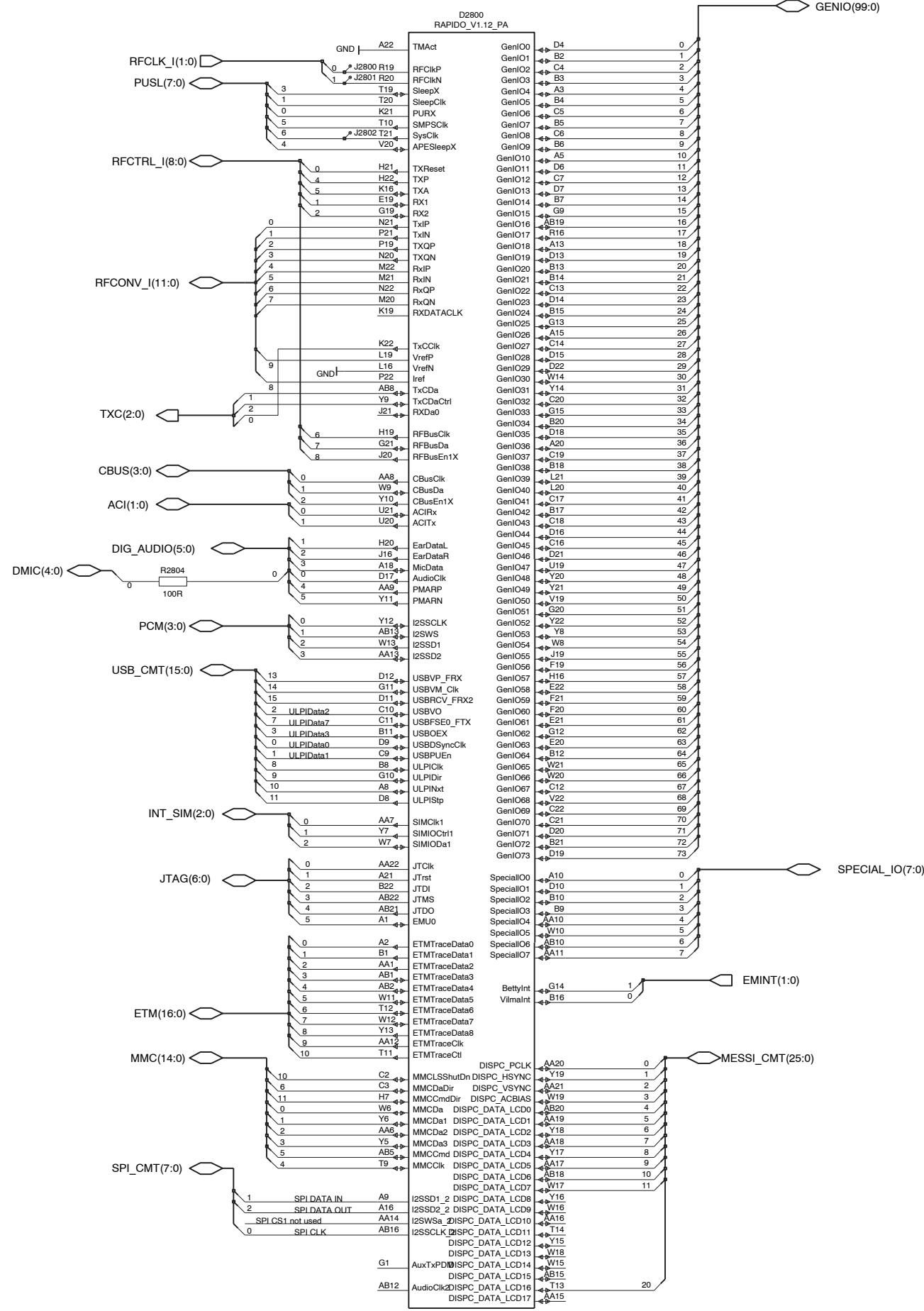

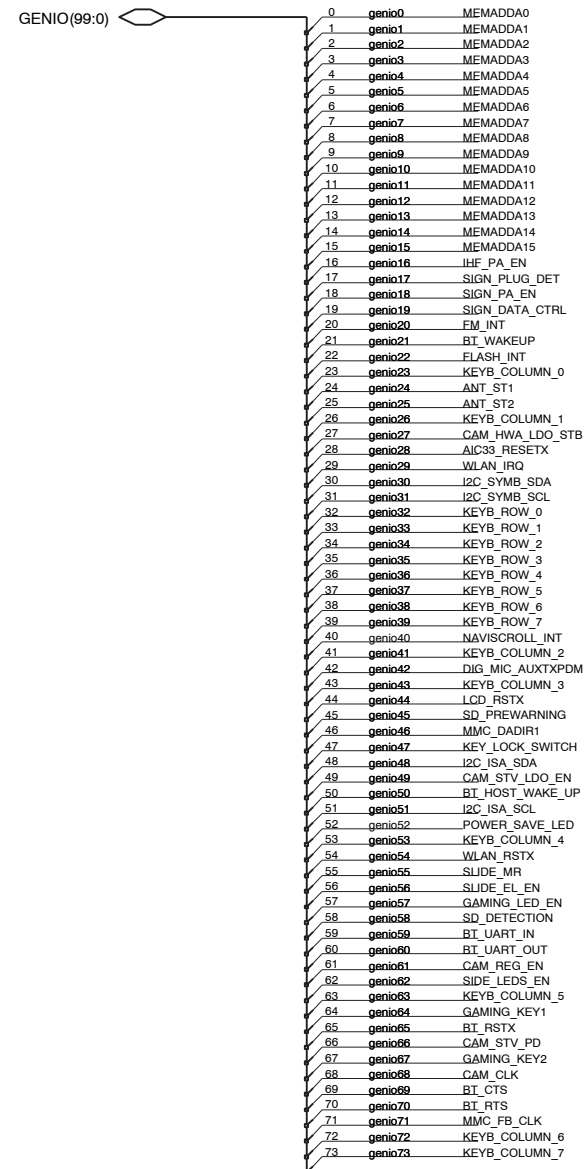

From RAPIDO sheet

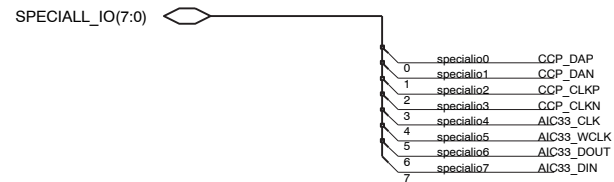
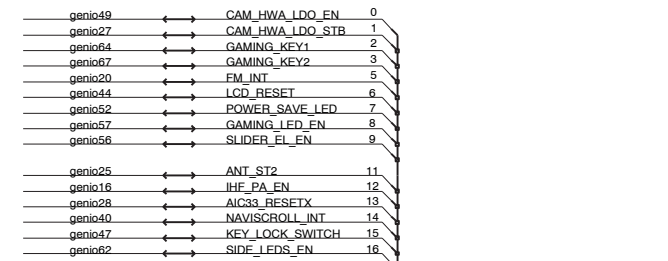
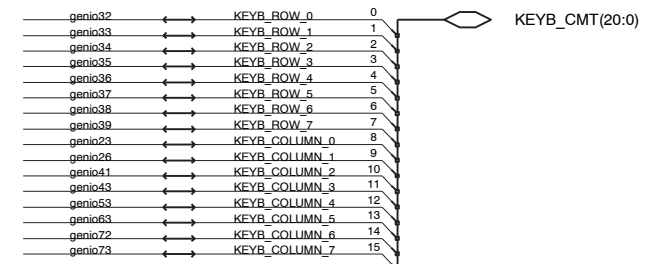
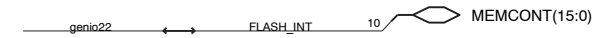
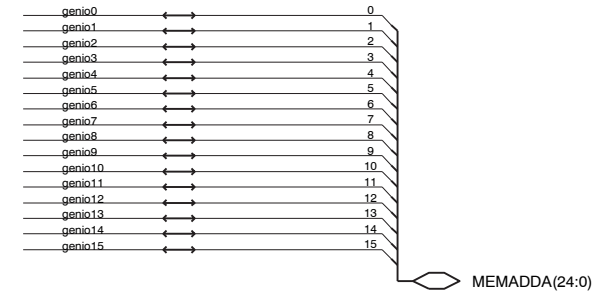
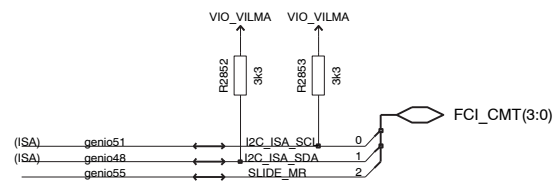
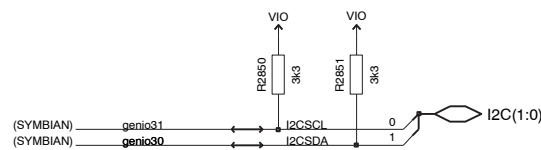
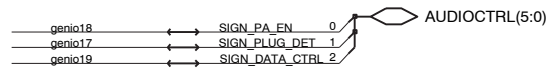
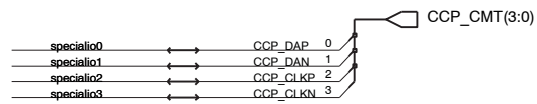
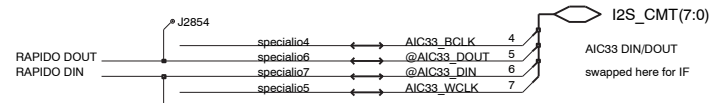
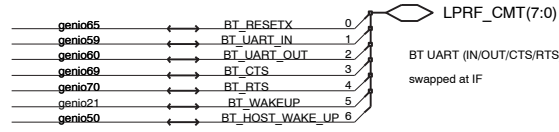
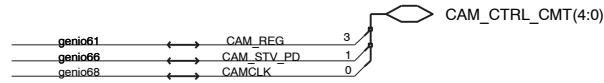
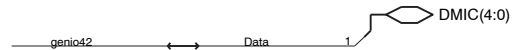
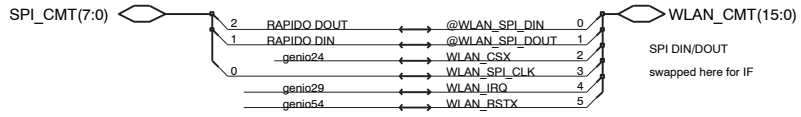

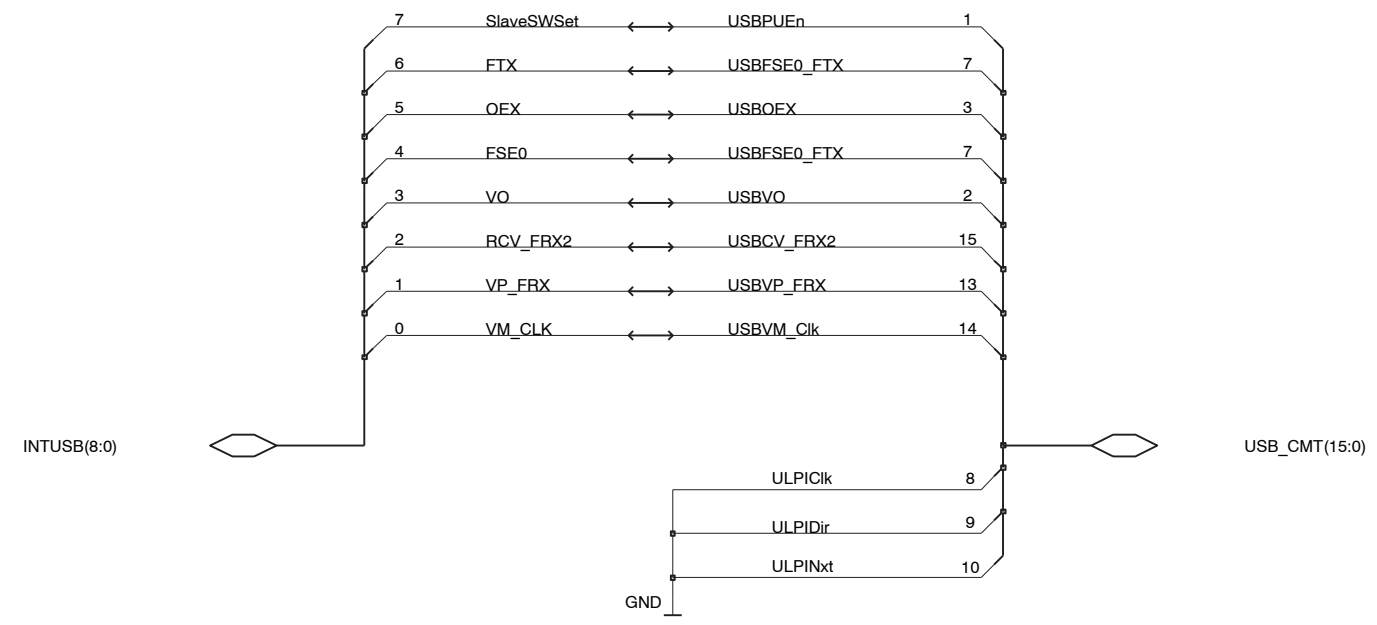

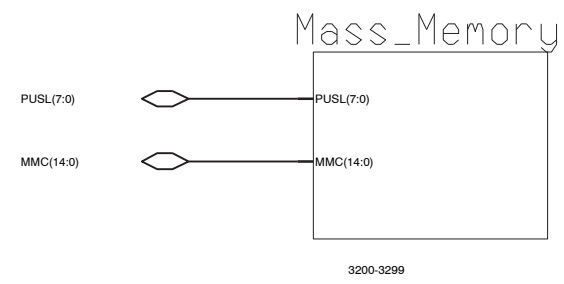
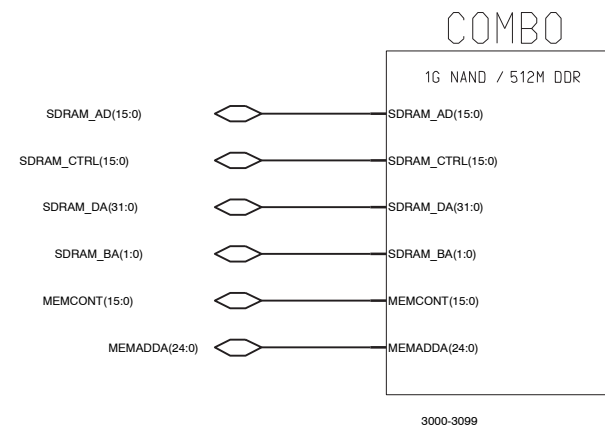

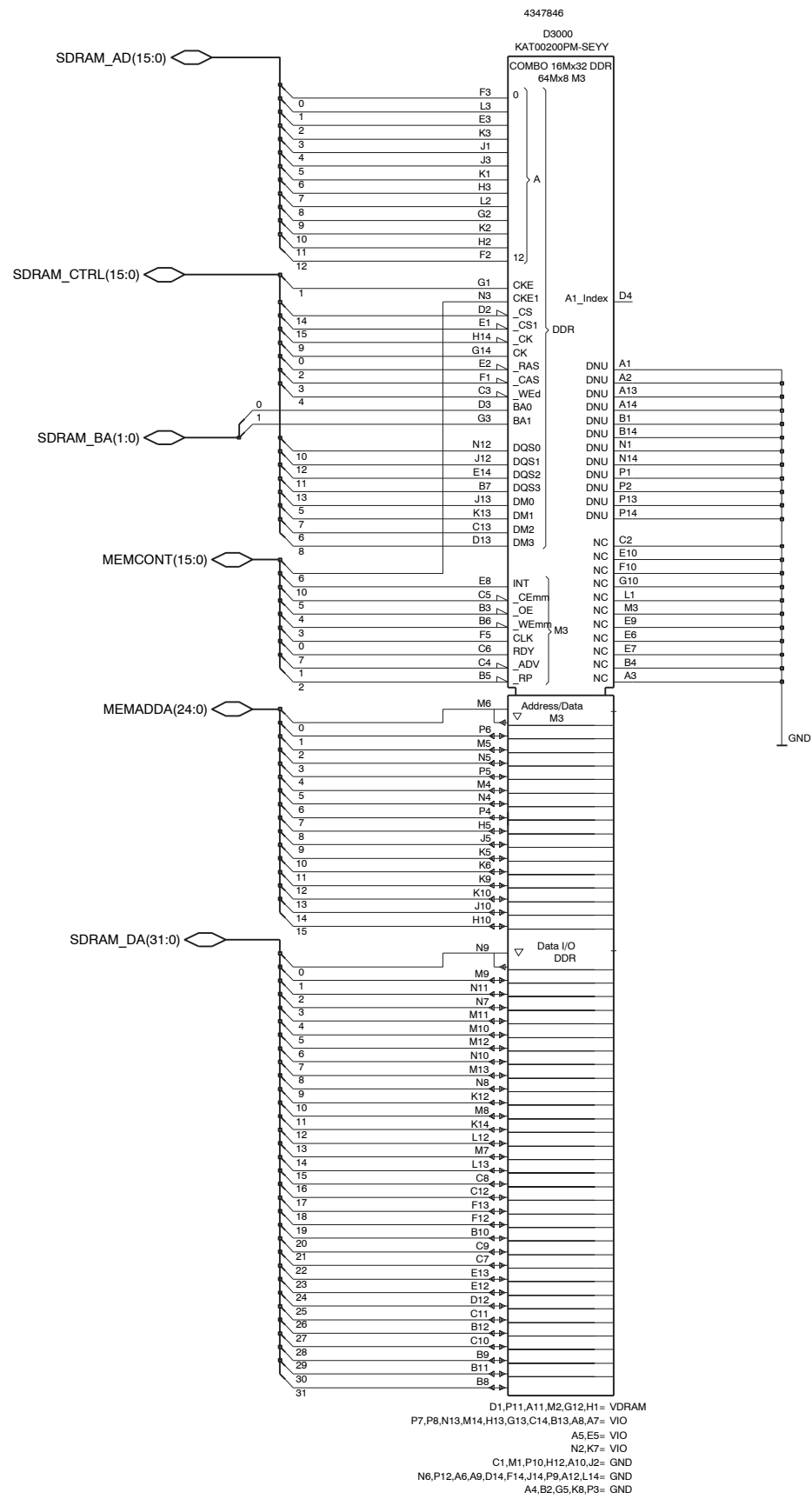
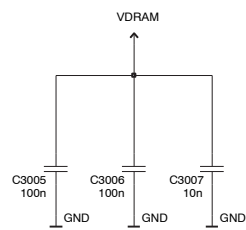
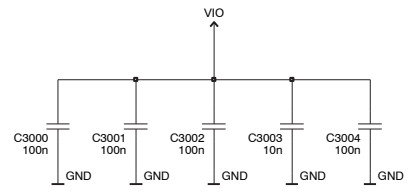

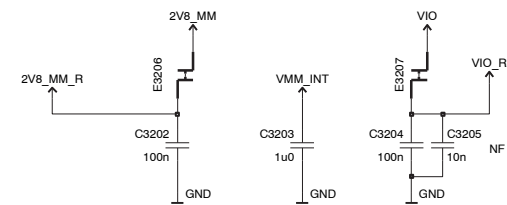
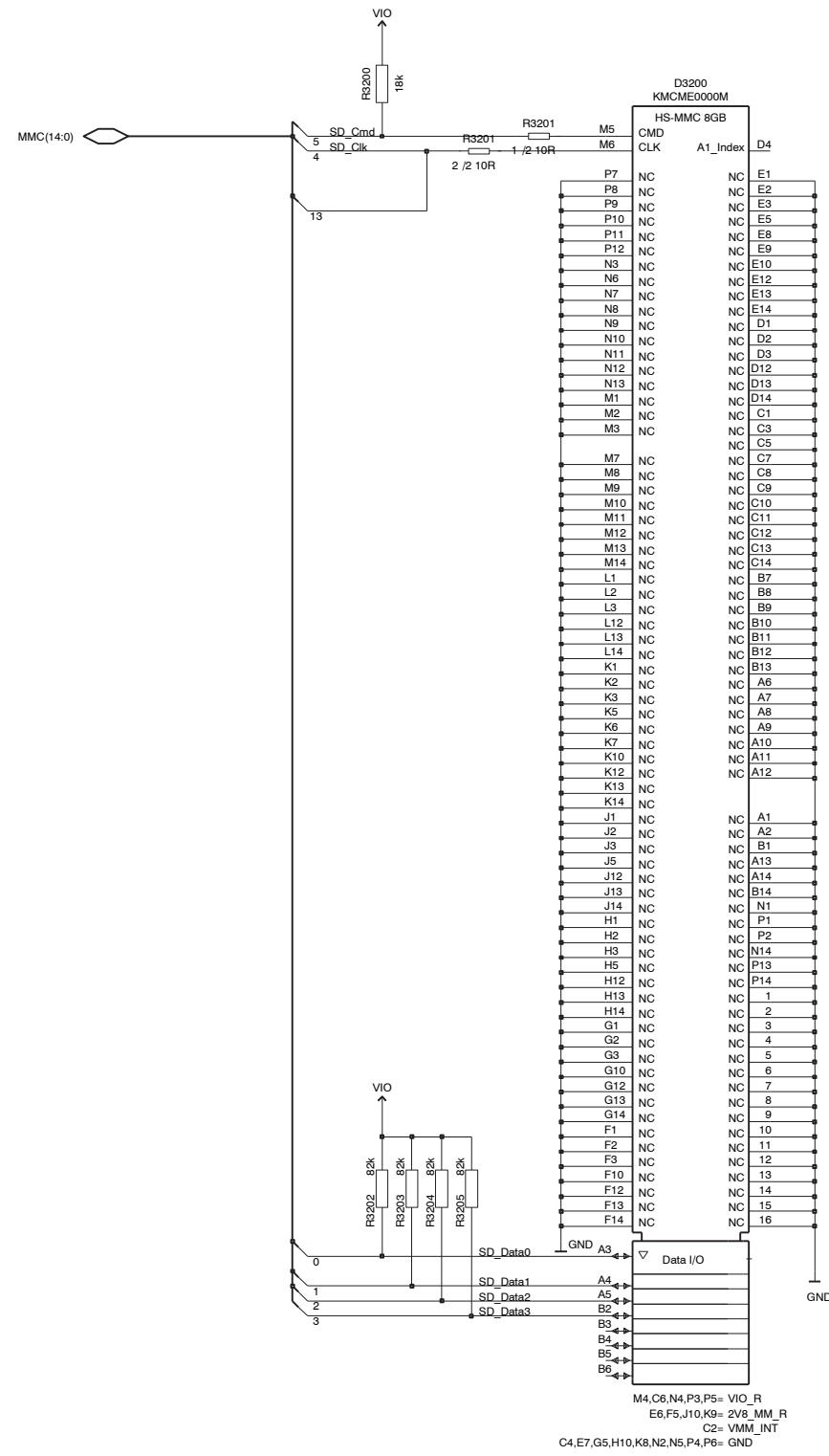
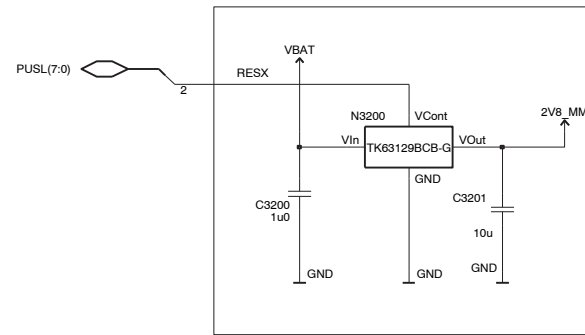

CBB5X

TOP SHEET

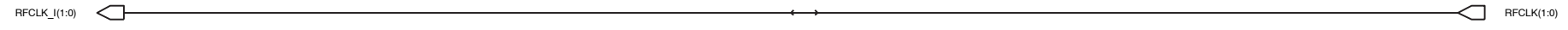

Own CLK on Wlan-sheet

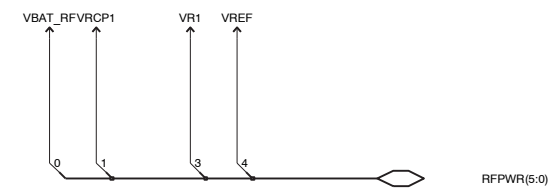

VRCP2 removed from VILMA
also removed from RF IF

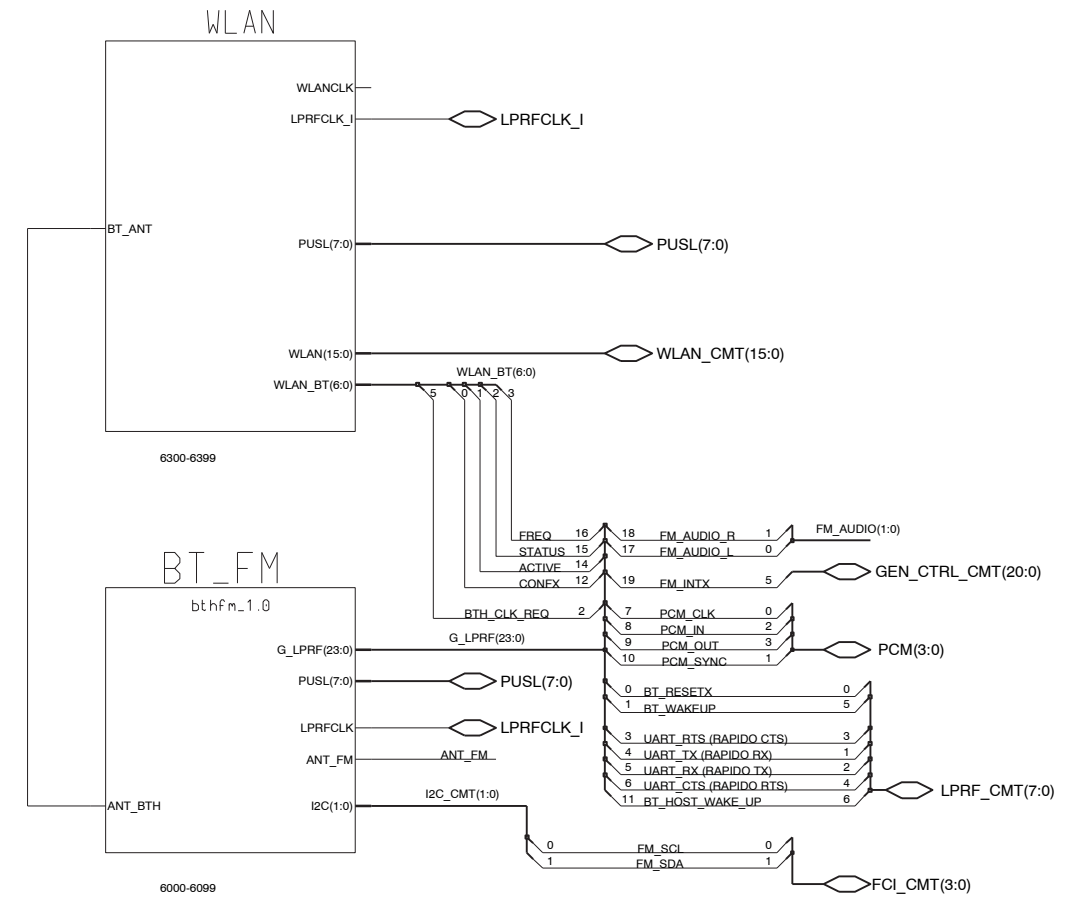
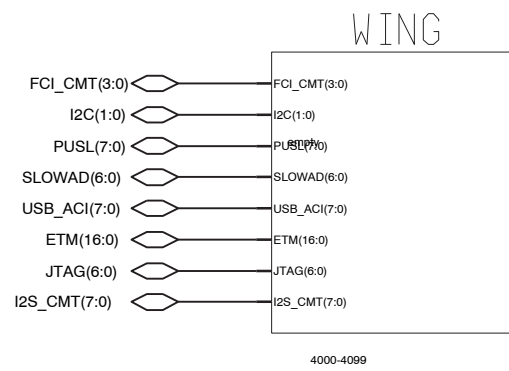
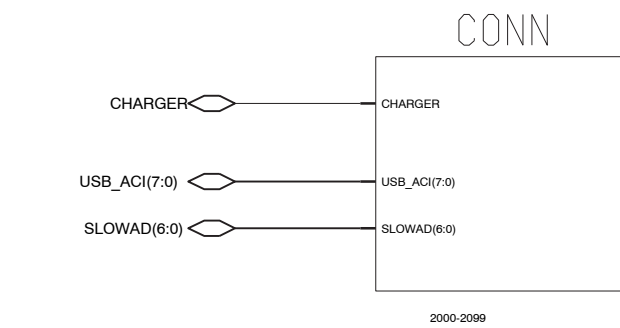
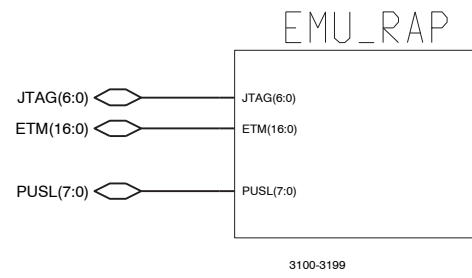
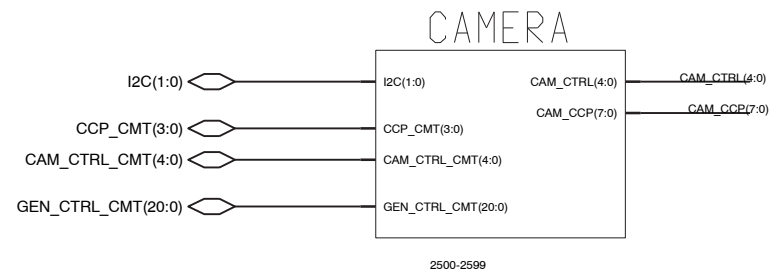
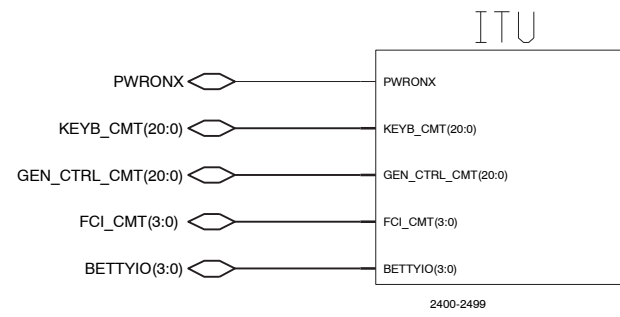
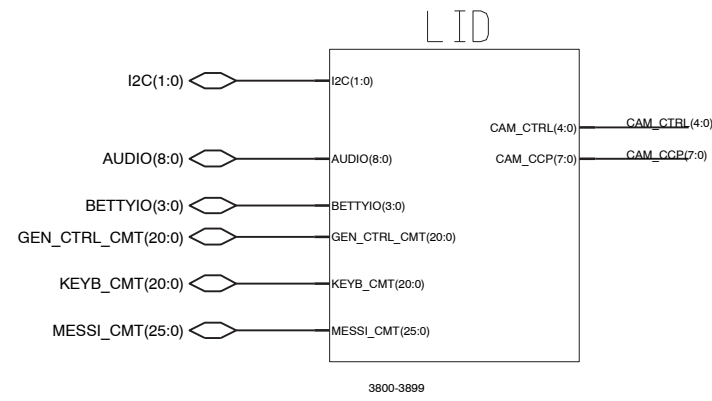
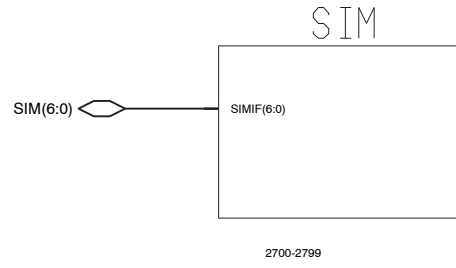
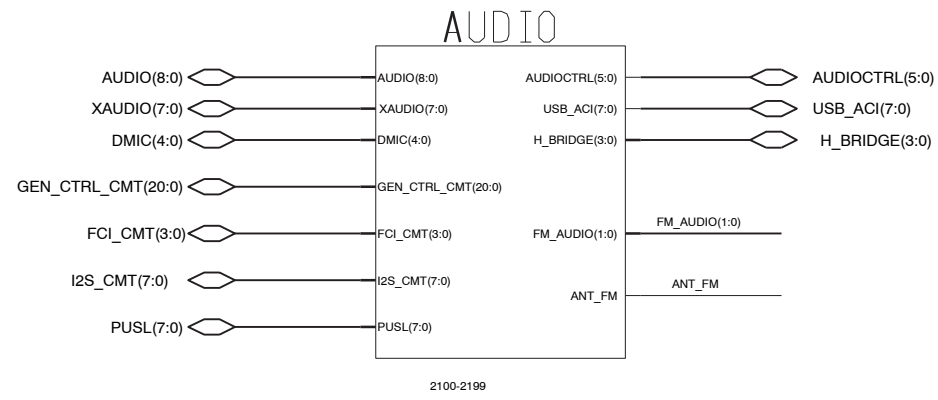

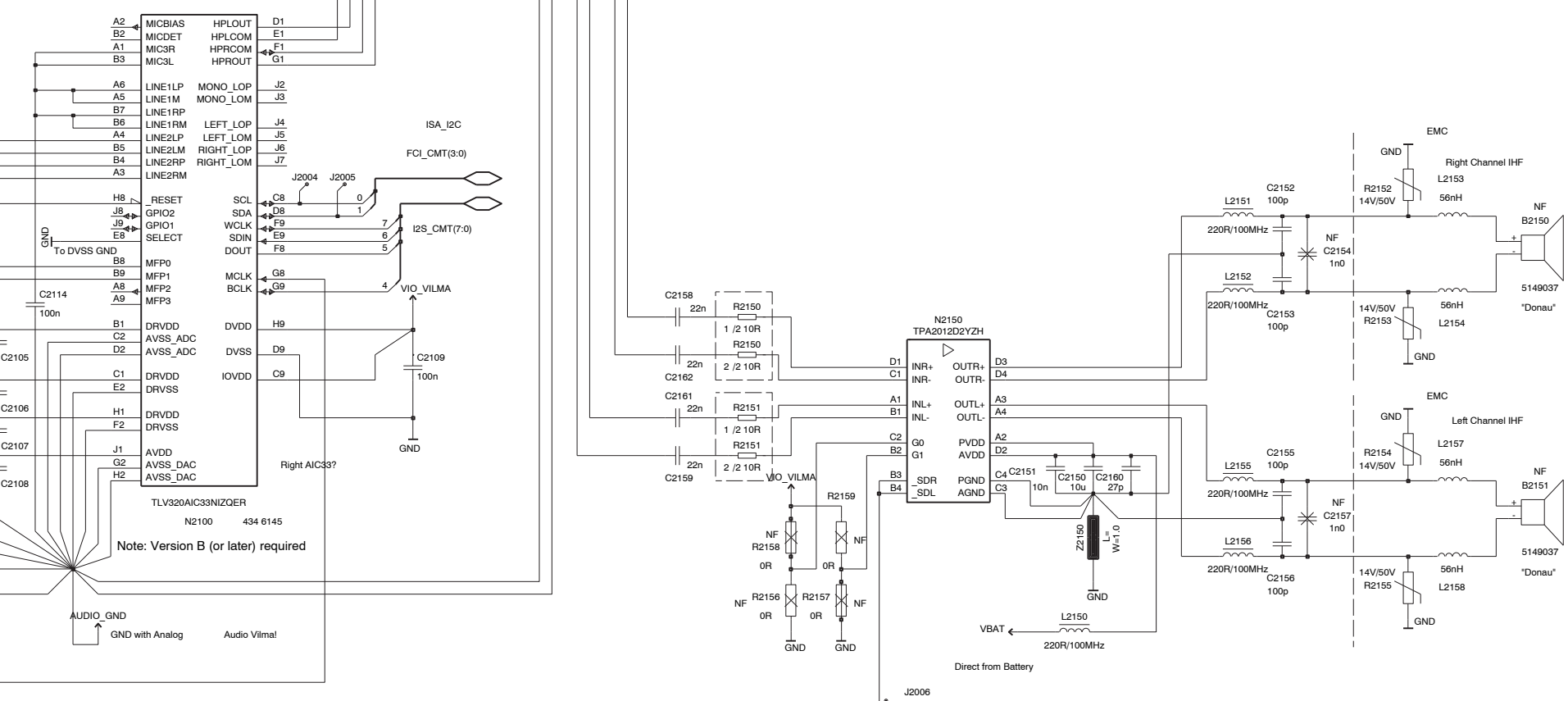
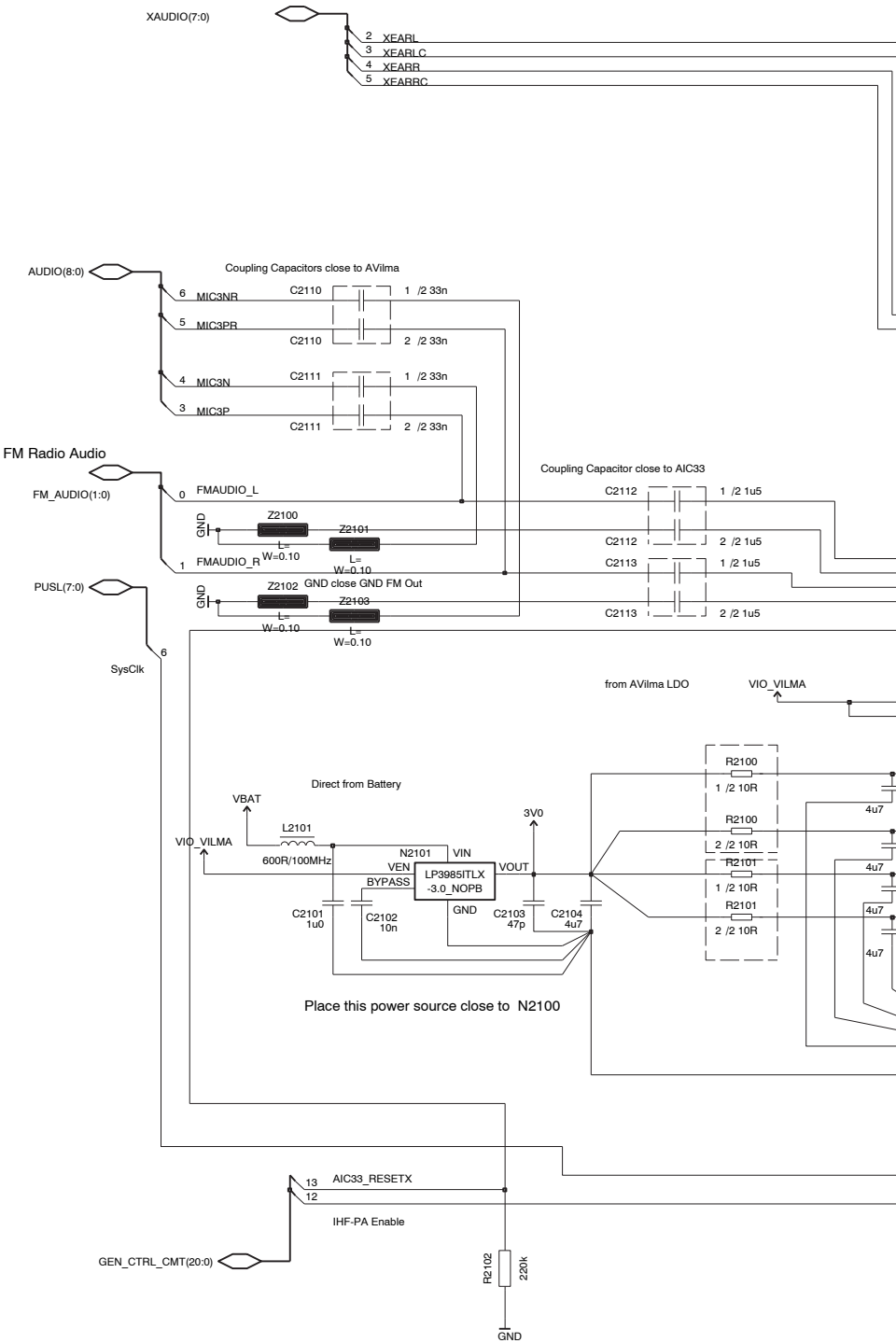
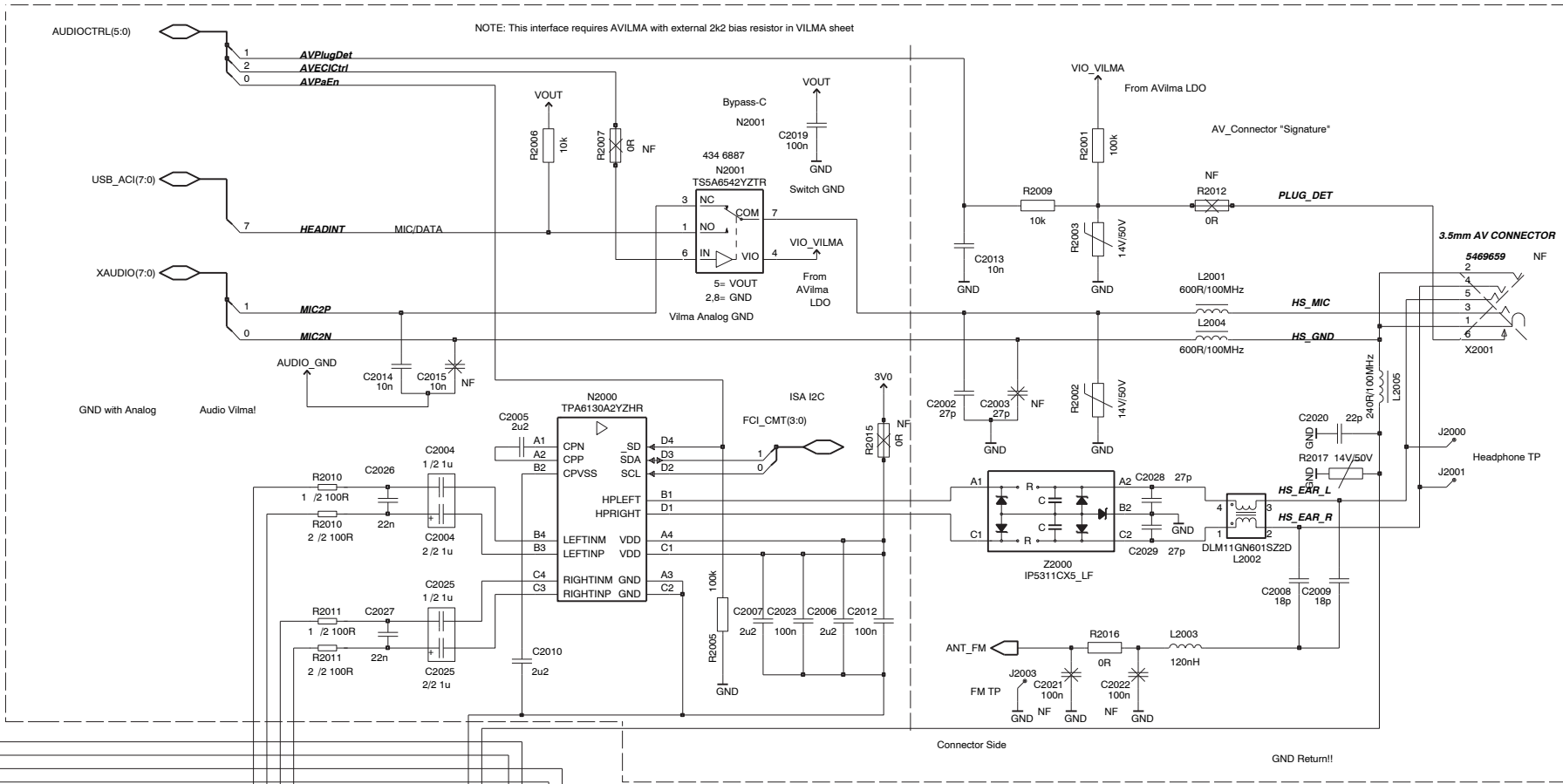
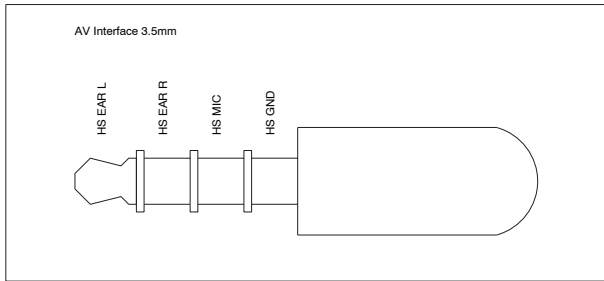

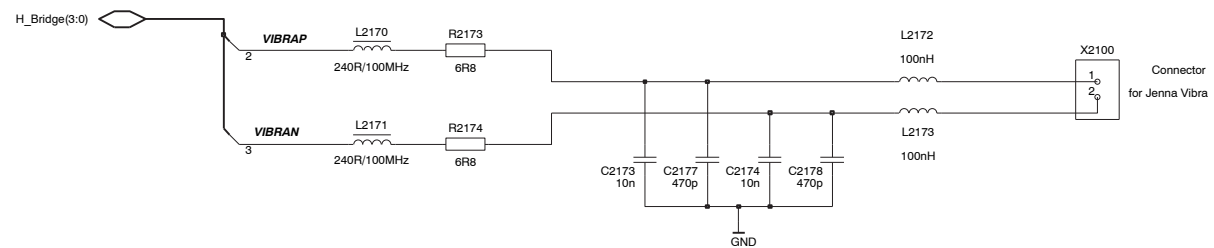
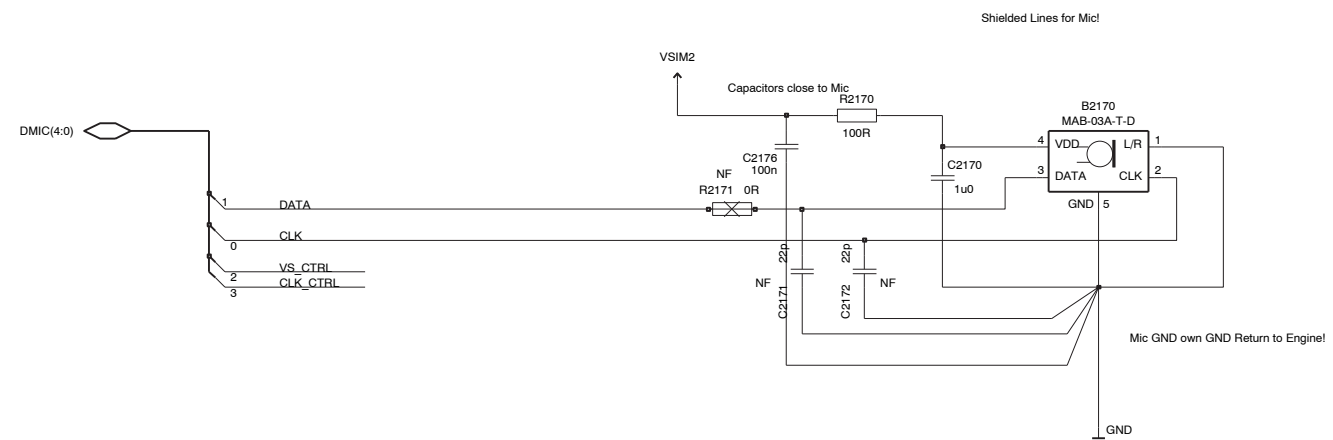

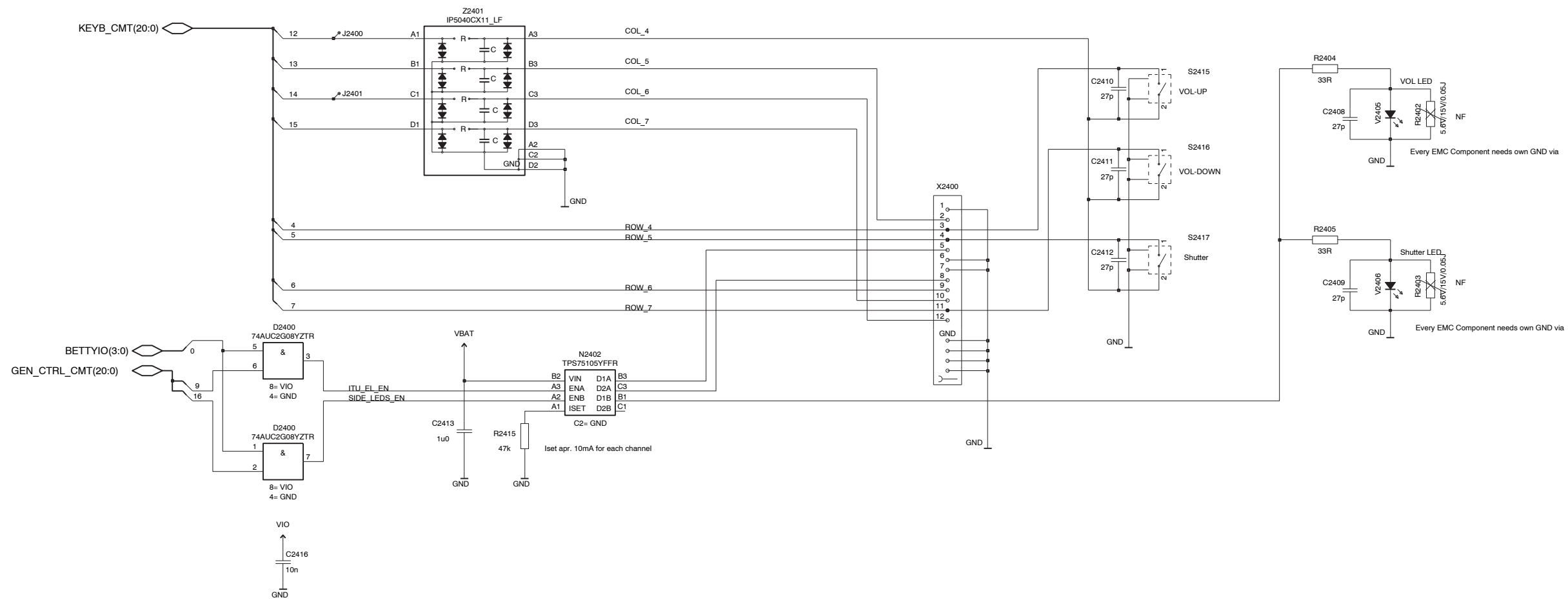
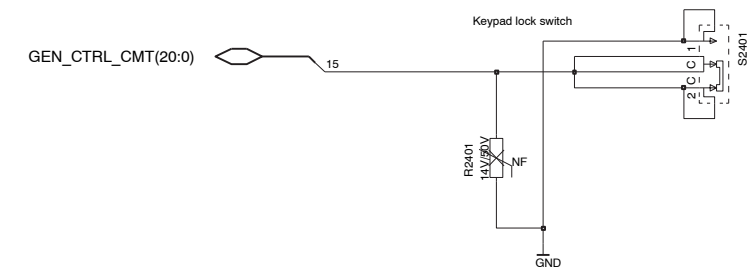
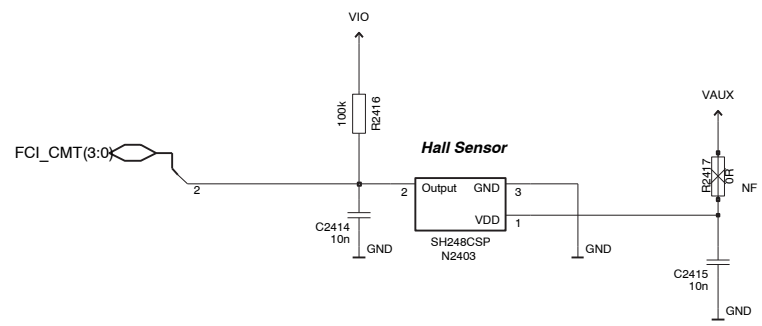
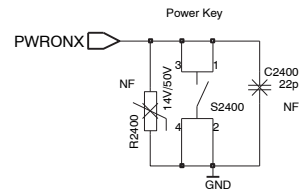

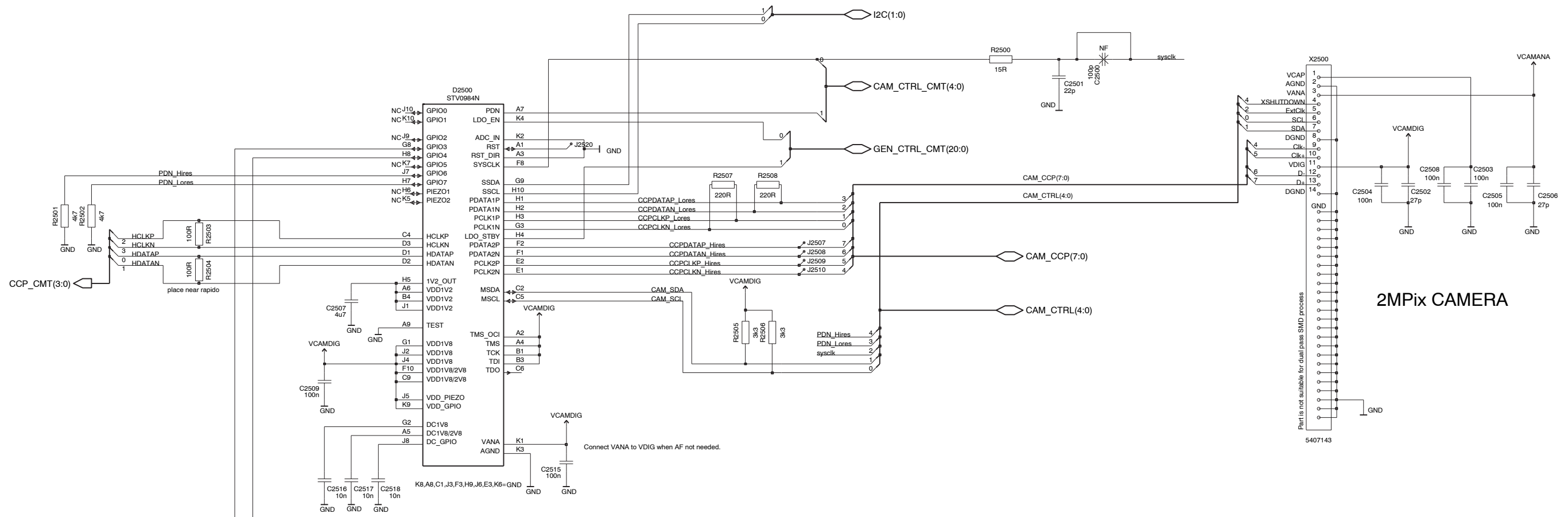

2MPix CAMERA

Flash LED

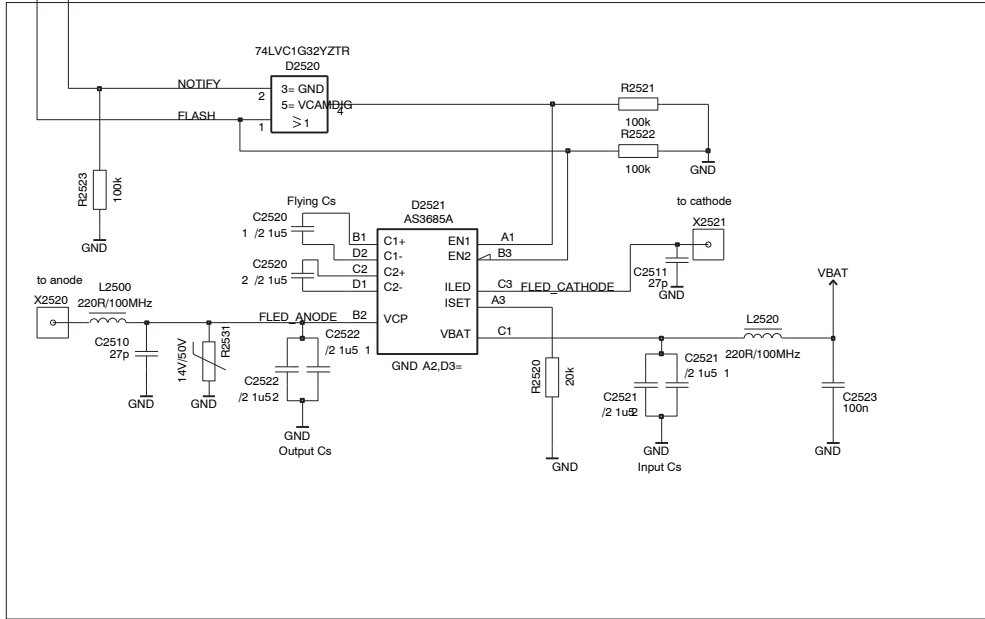

Camera Power Supply

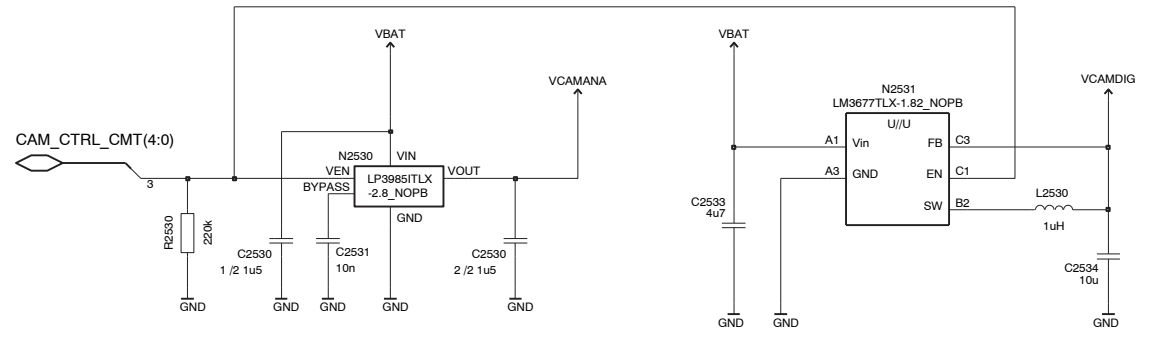

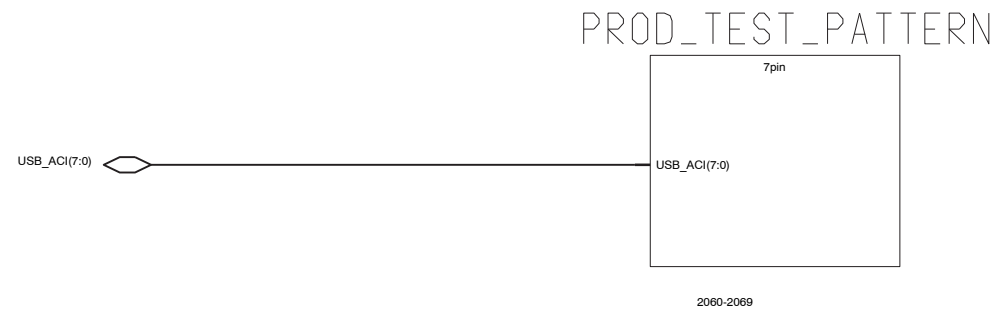
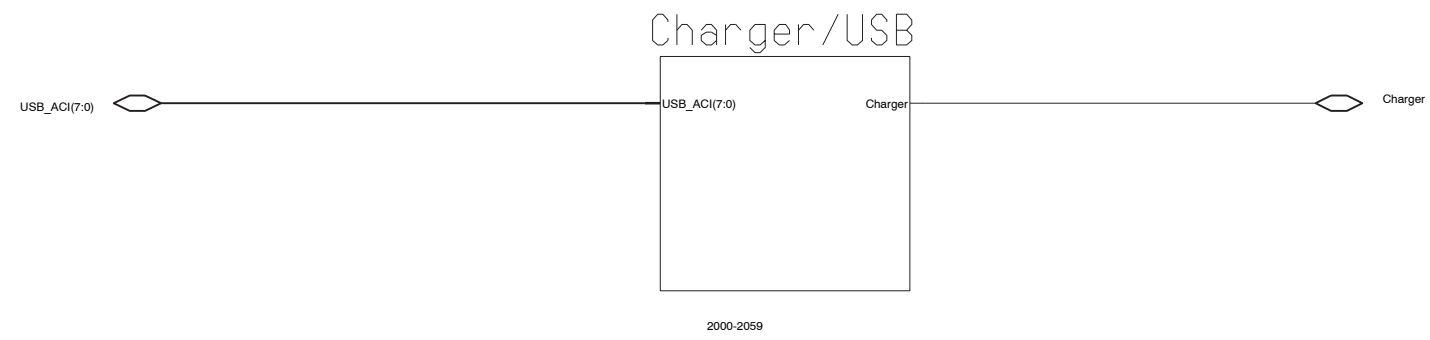

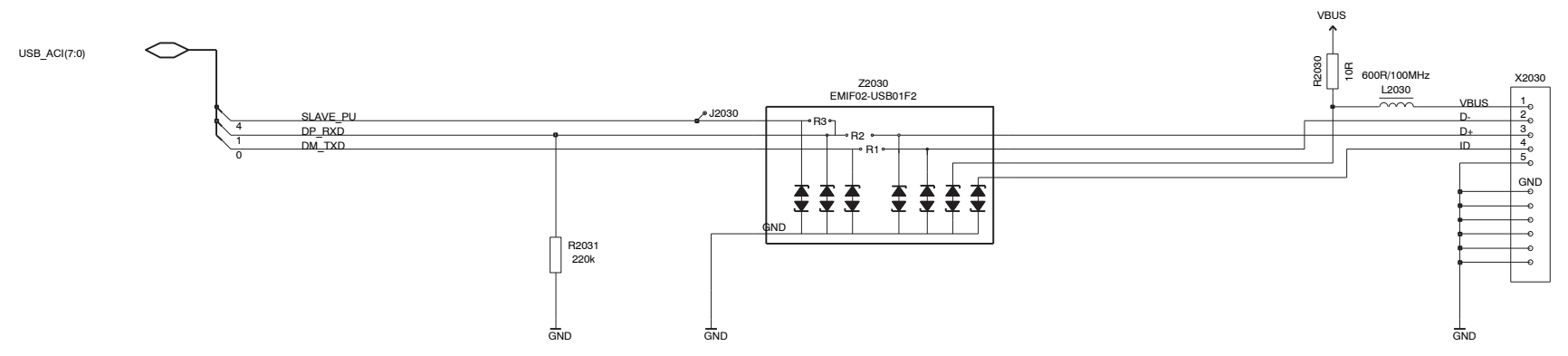
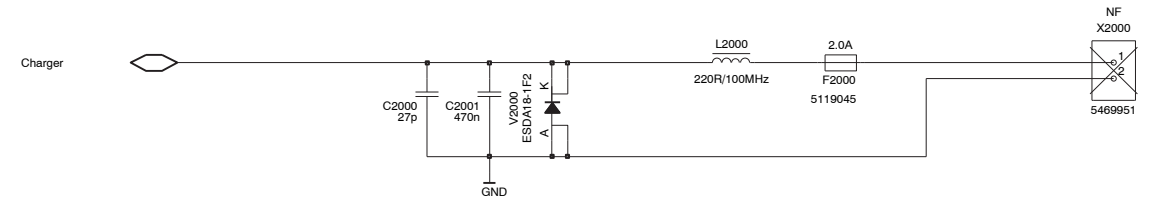

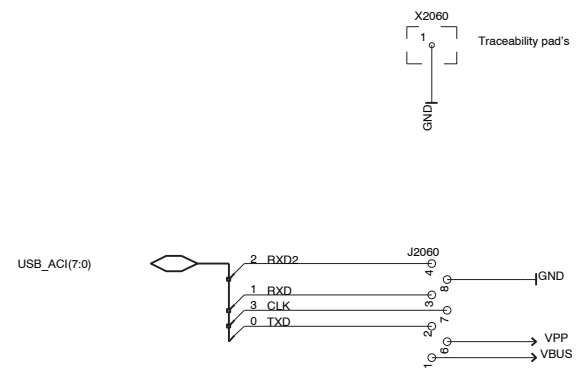

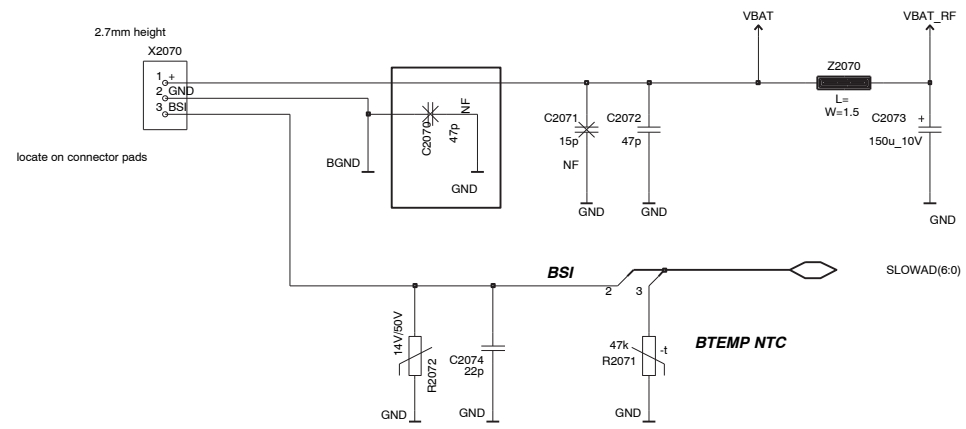

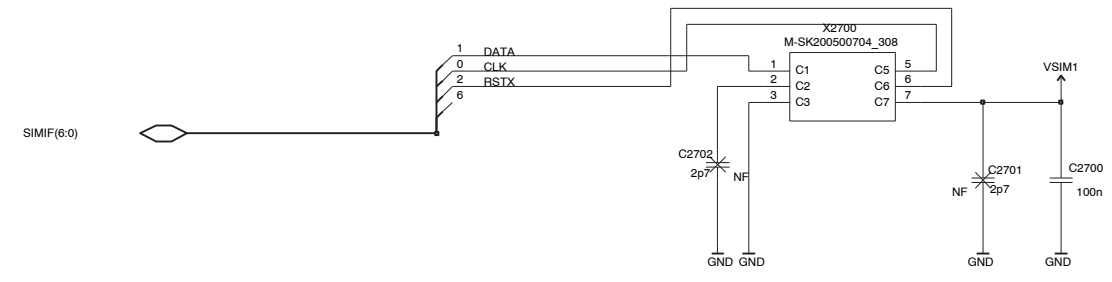

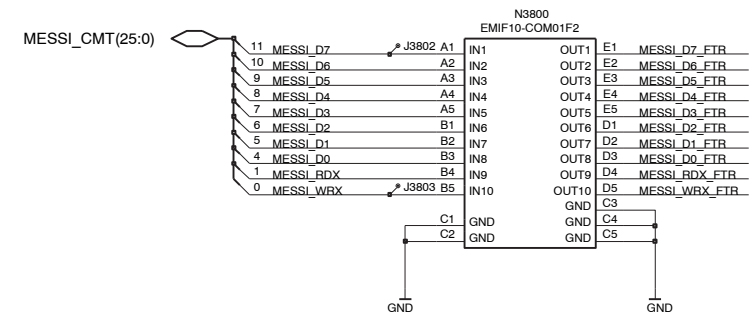
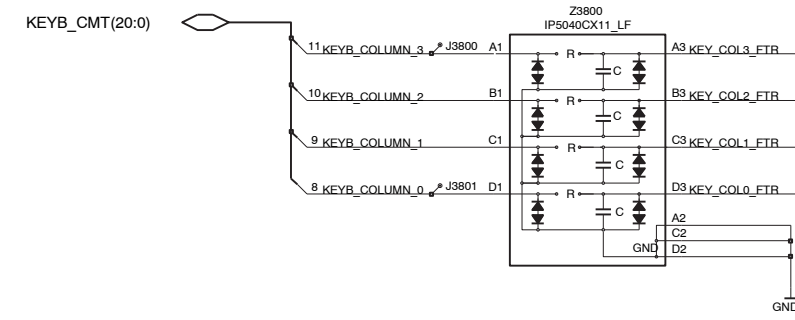
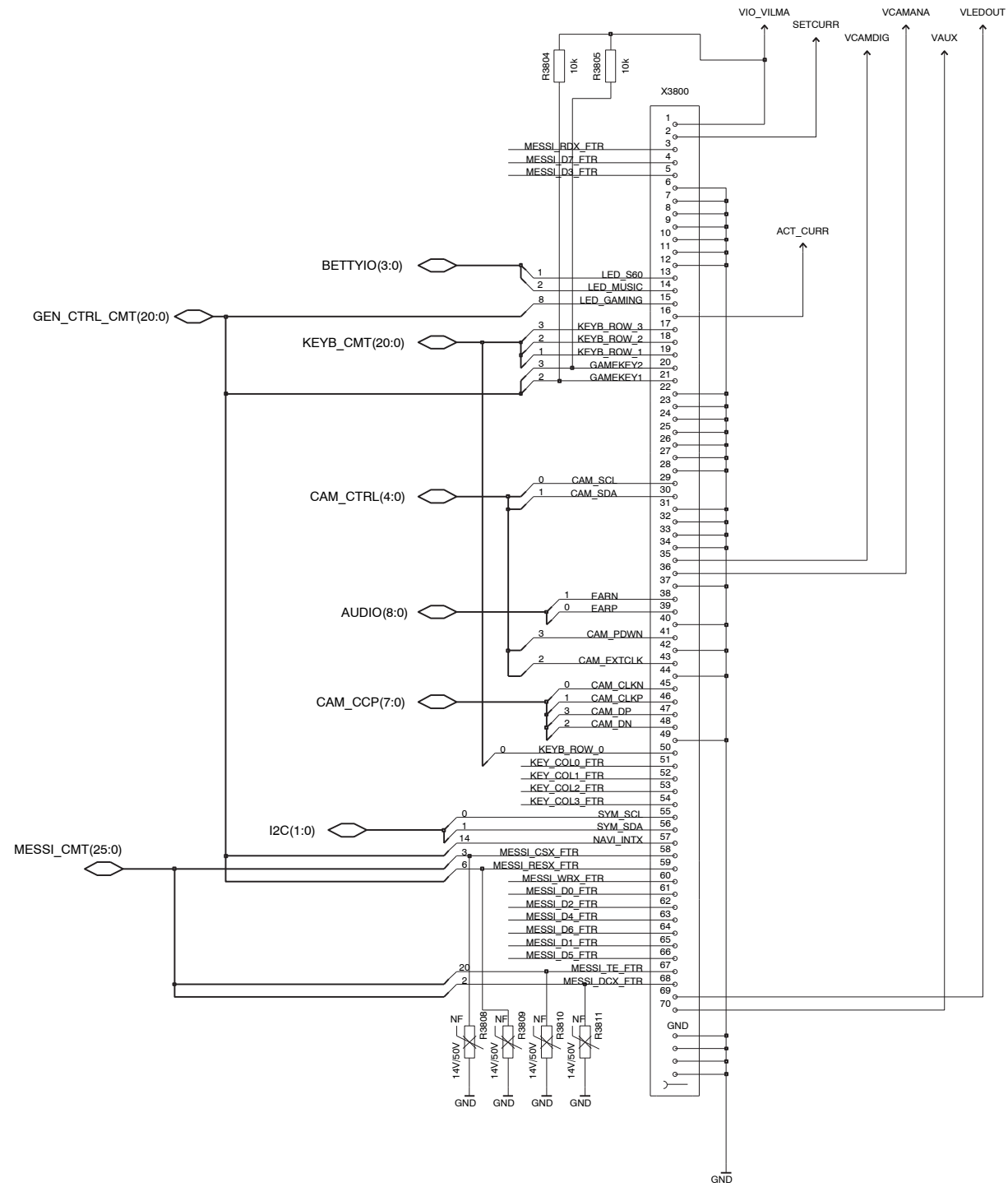

Activity LED Driver

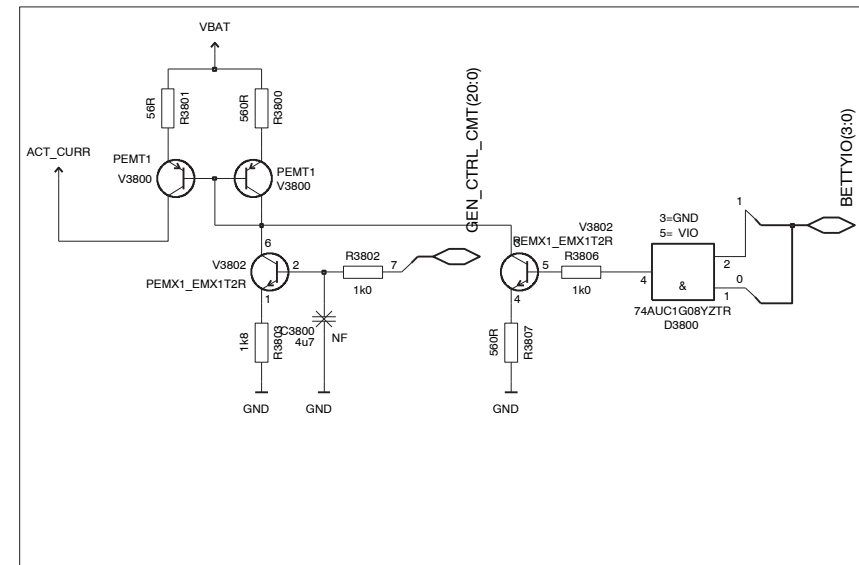

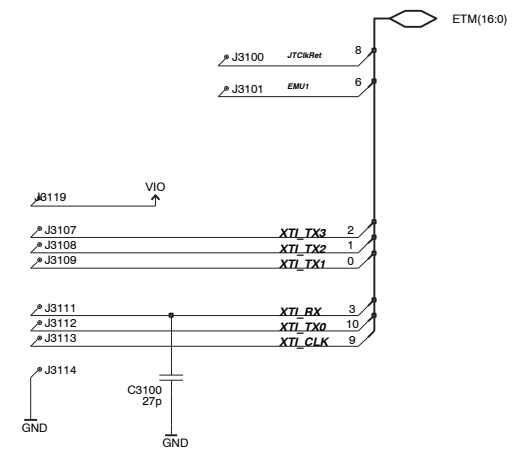
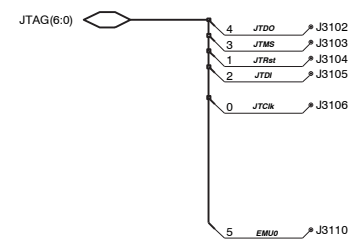

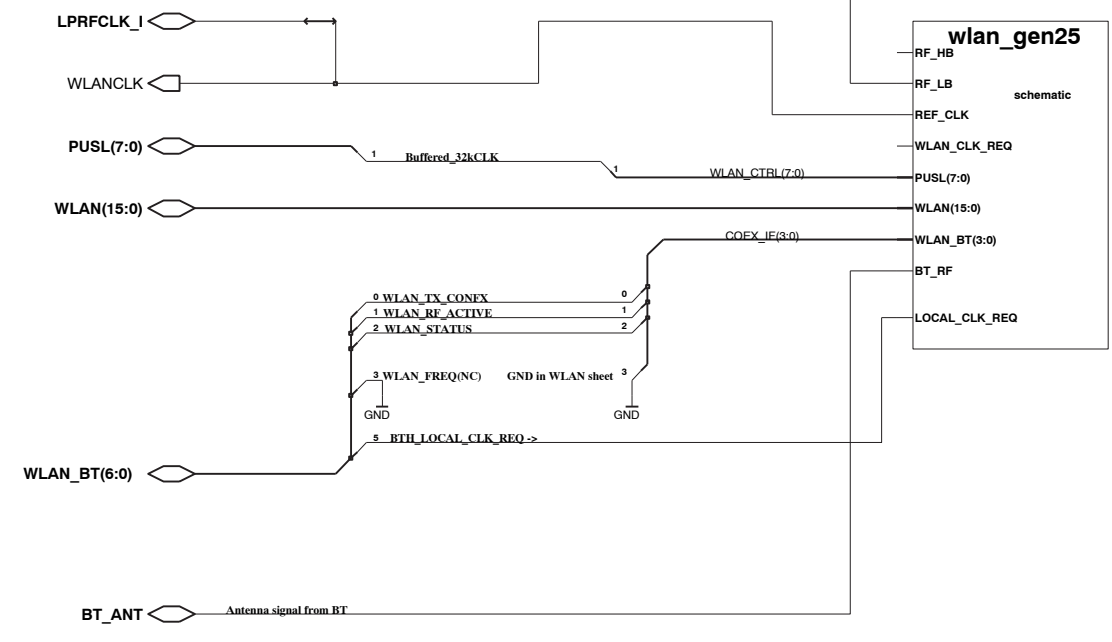
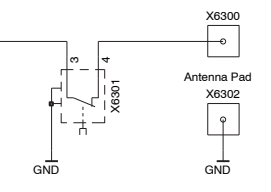
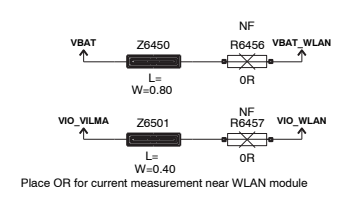

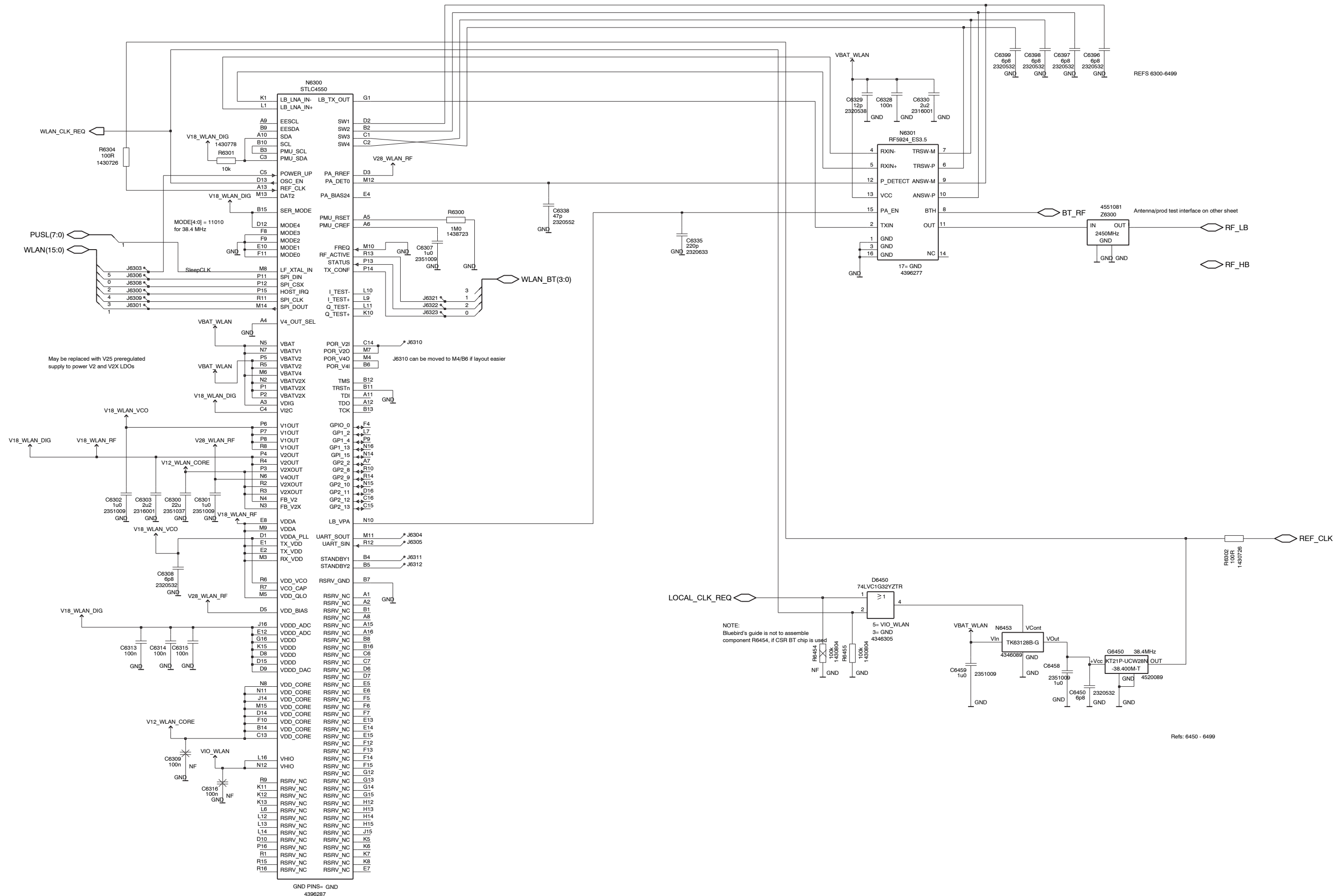

REFS 6300-6499

REFS: 6450 - 6499

NOTE:
Bluebird's guide is not to assemble component R6454, if CSR BT chip is used

GND PINS= GND
4396287

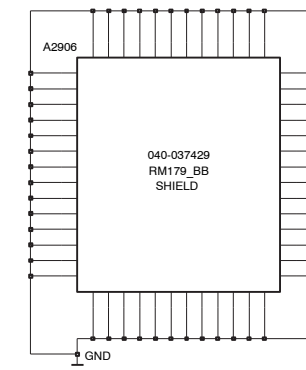
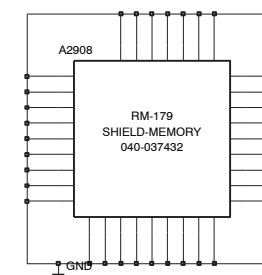
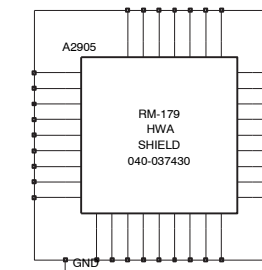
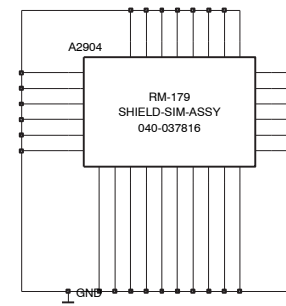
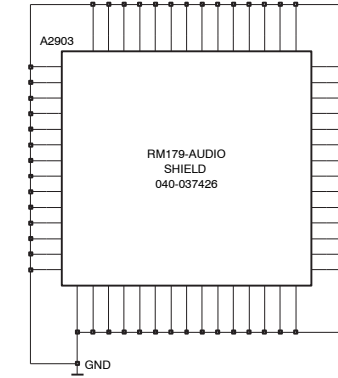
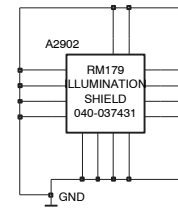
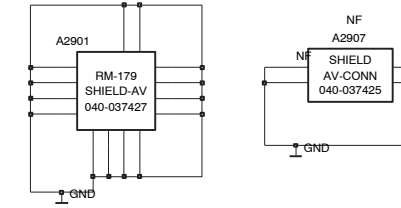
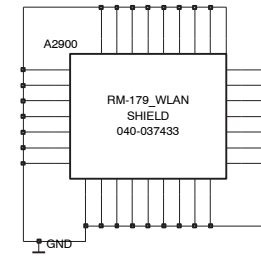

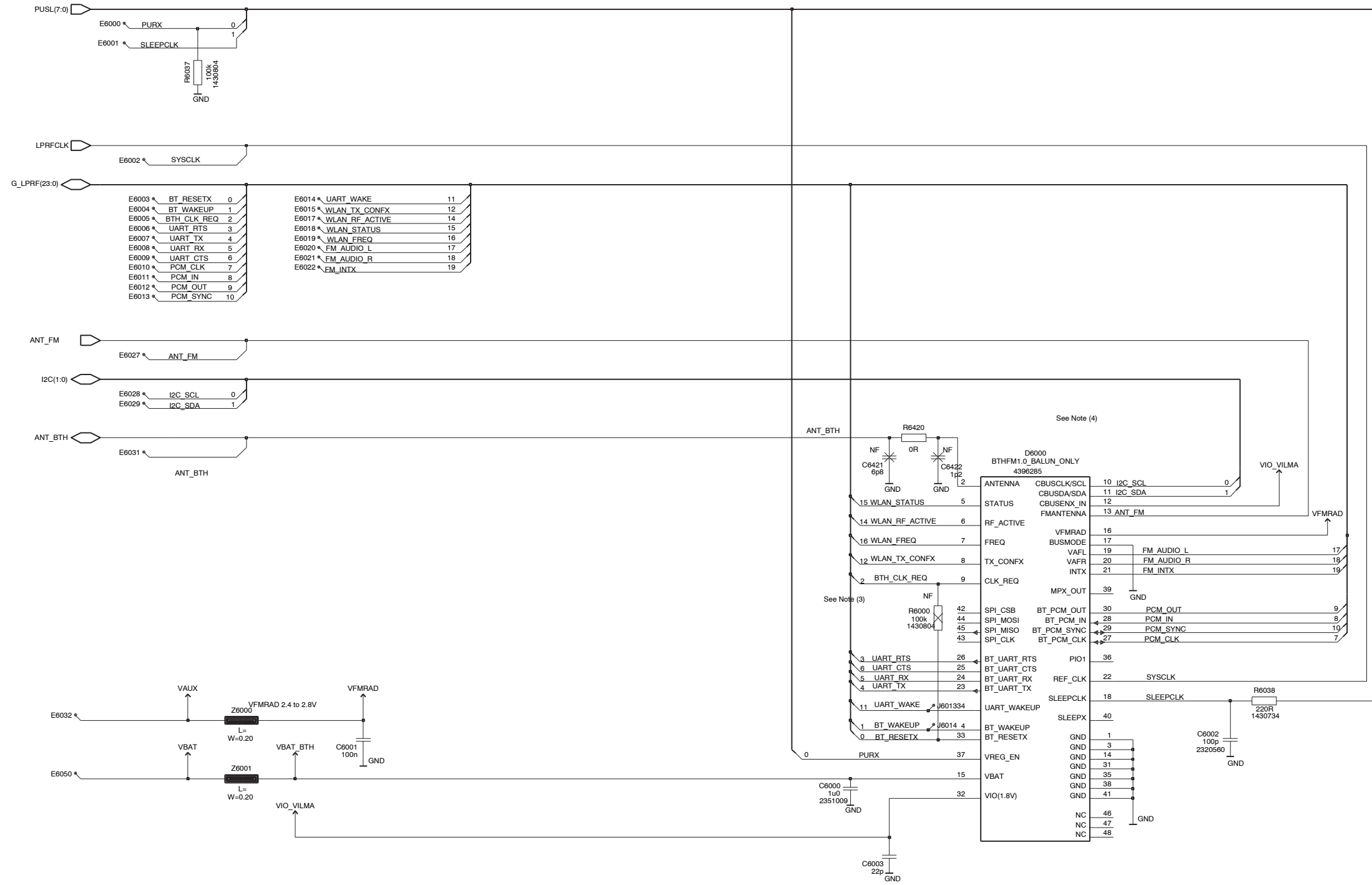

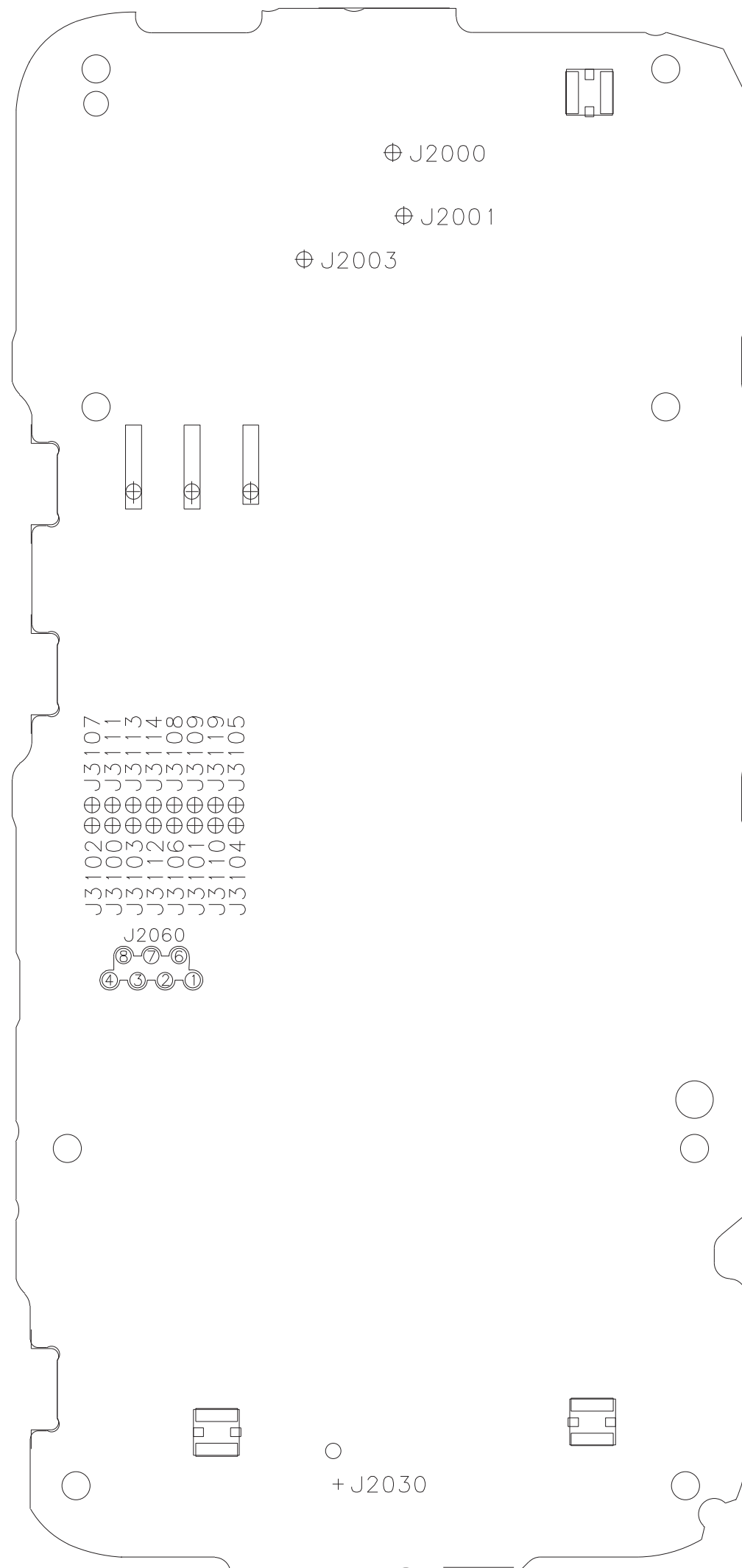

2cg_07a_tstdrw_b.pdf

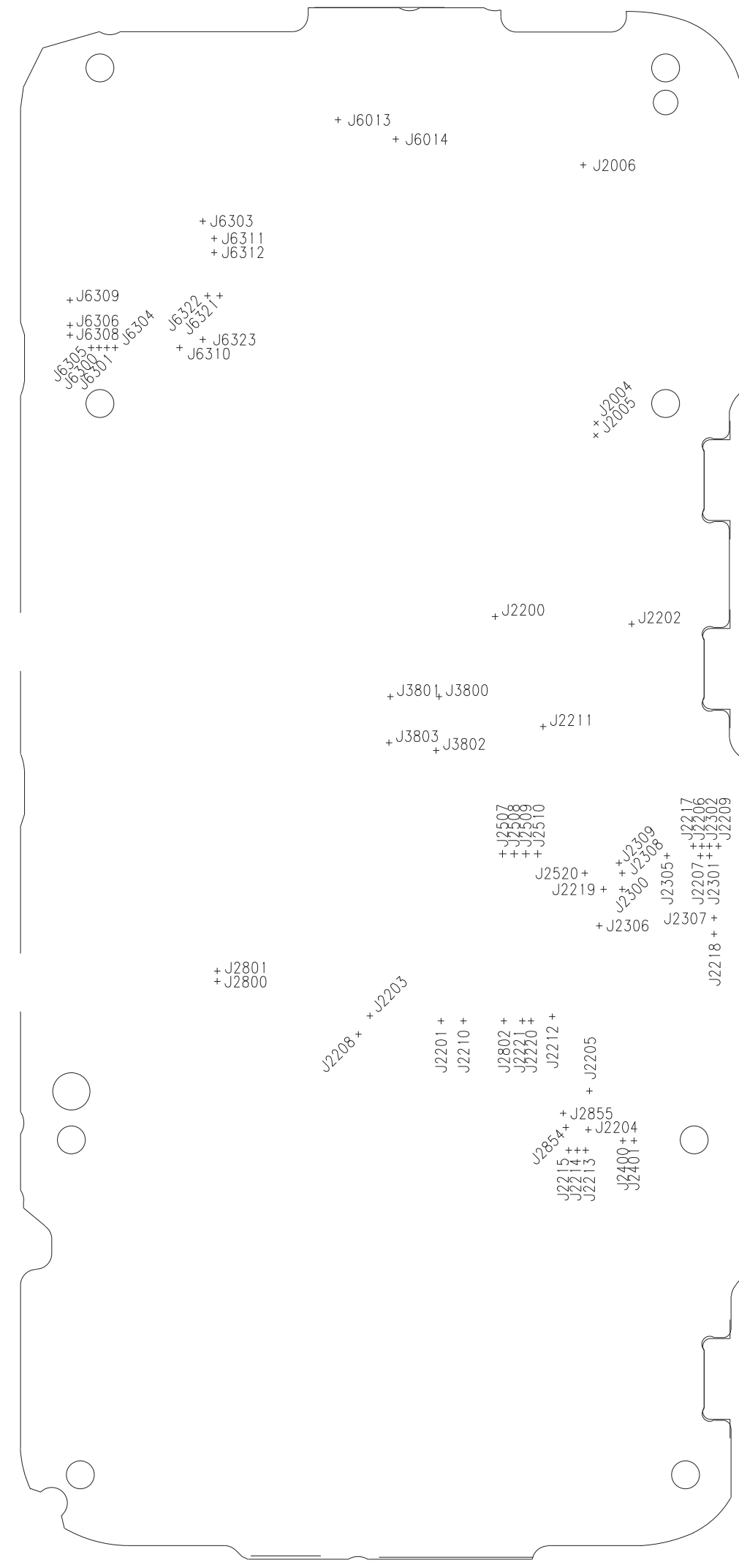

2cg_07a_tstdrw_t.pdf

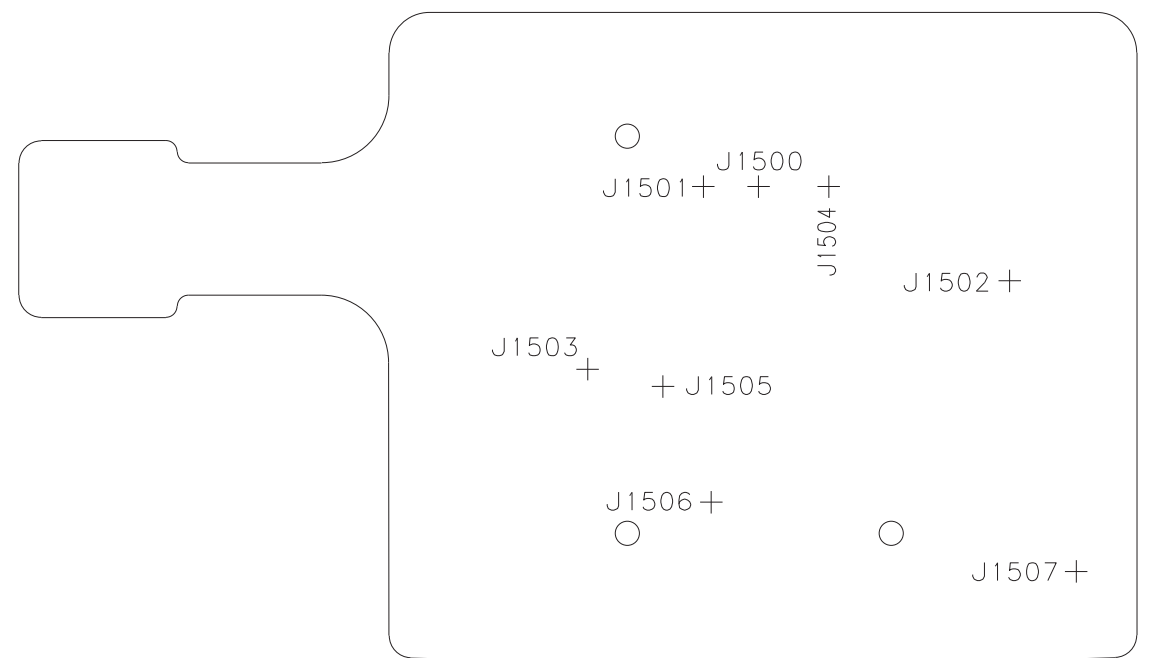
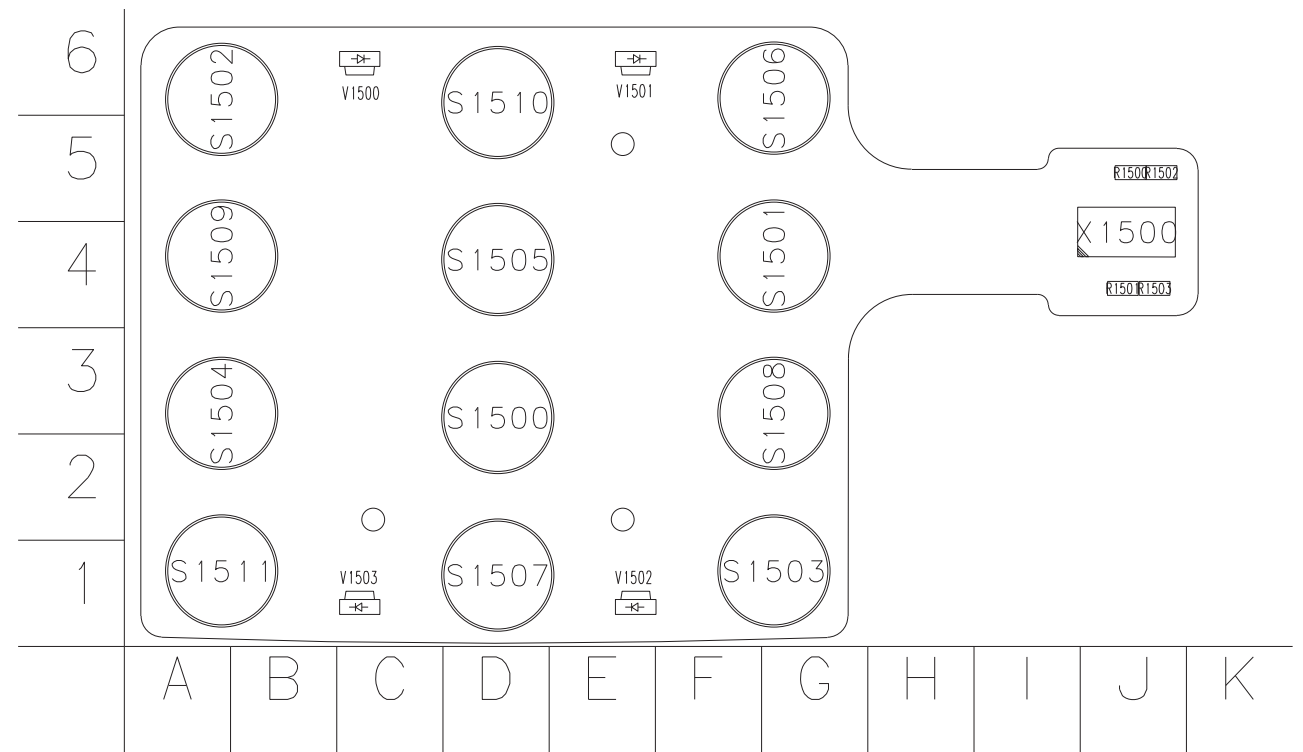
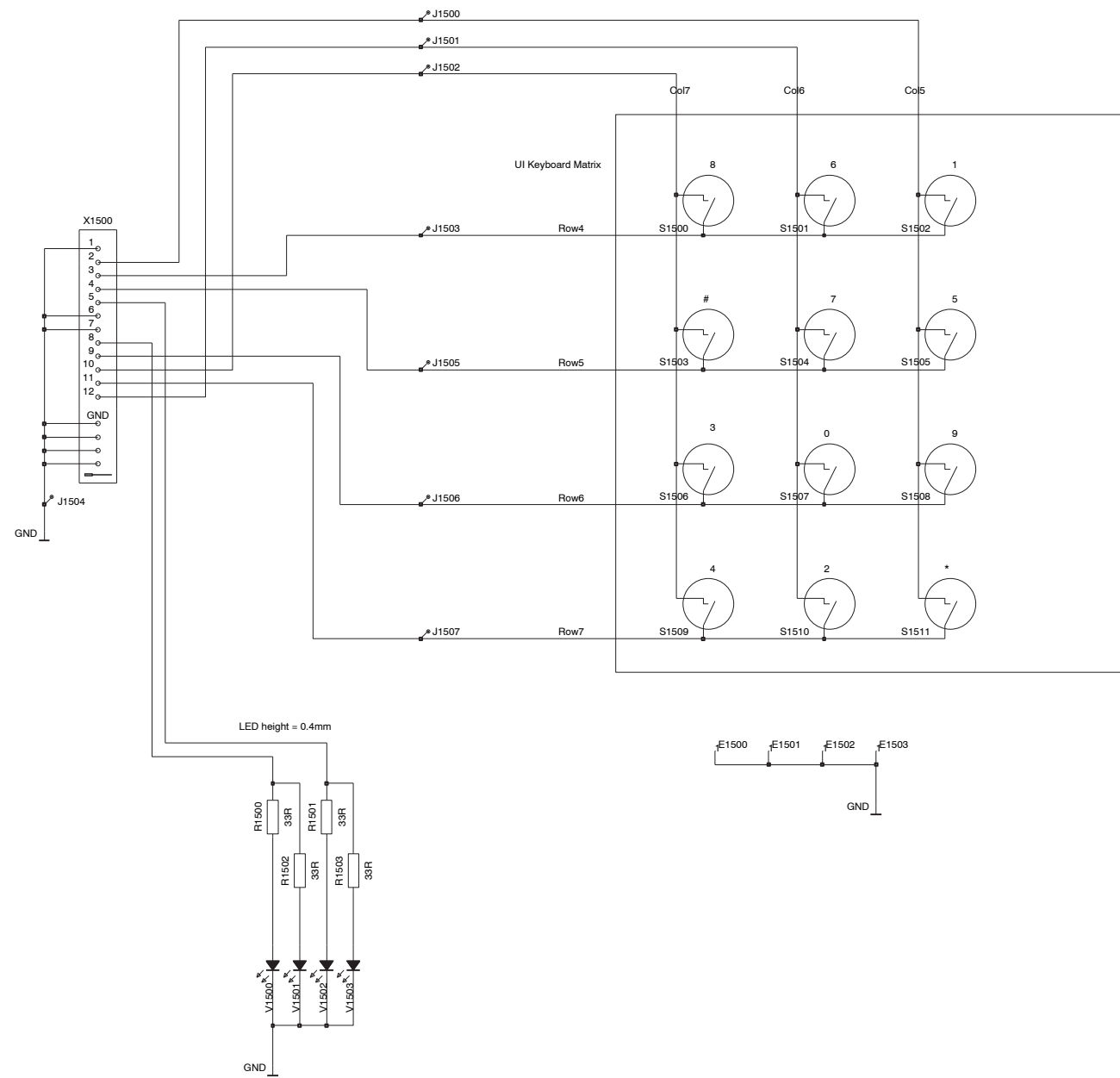

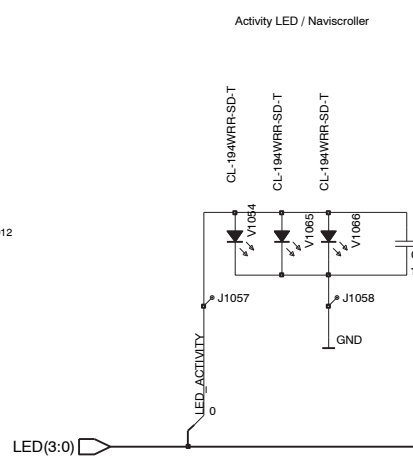
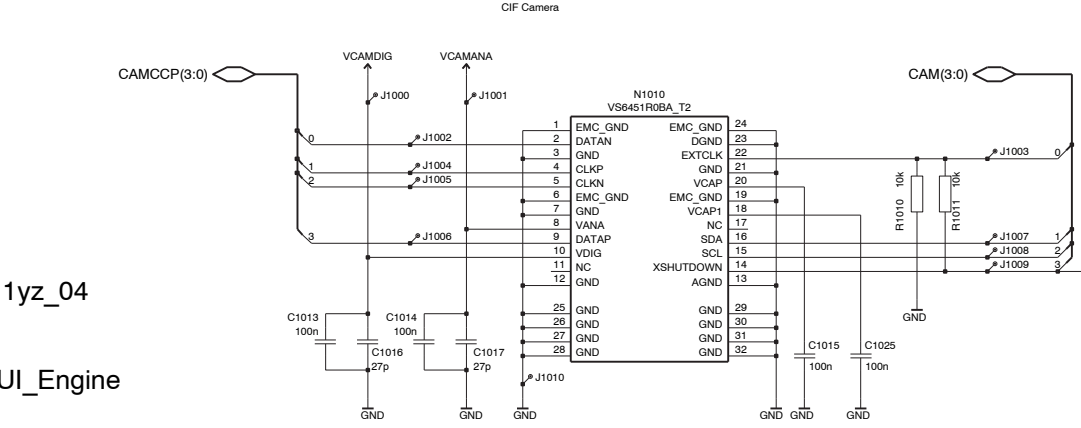
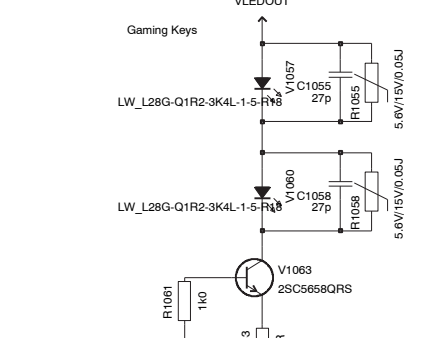
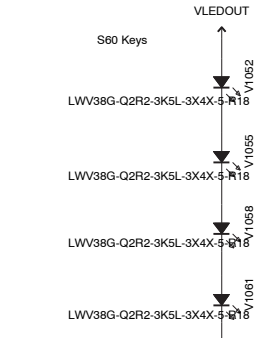
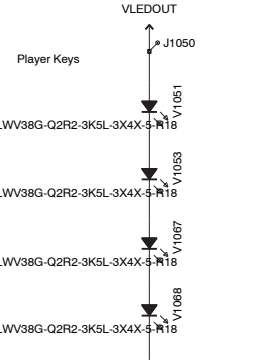
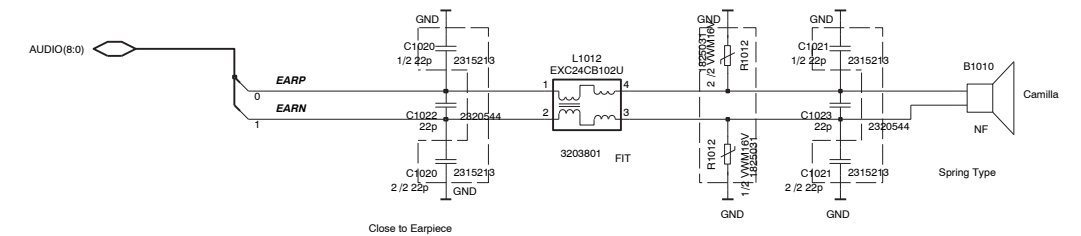
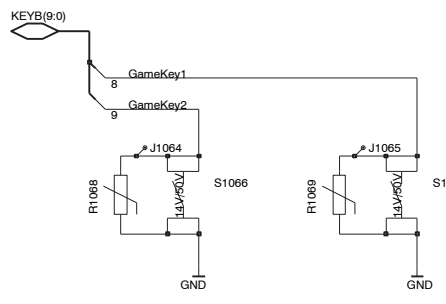
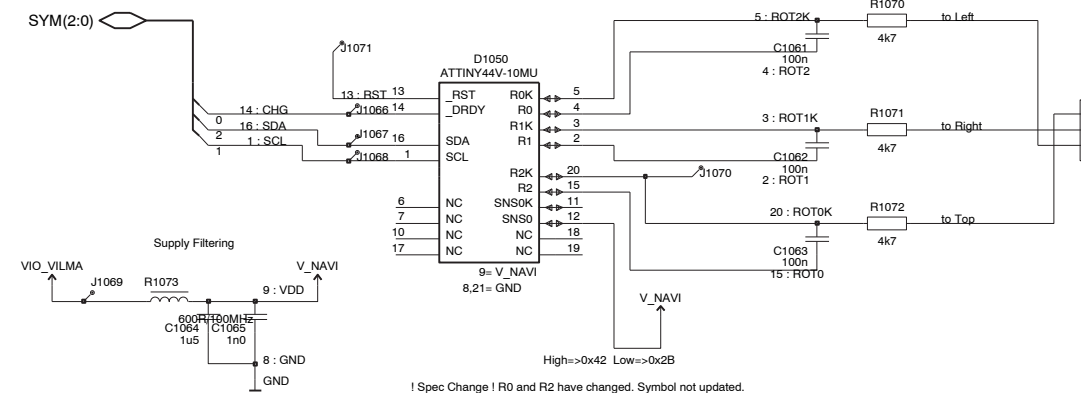
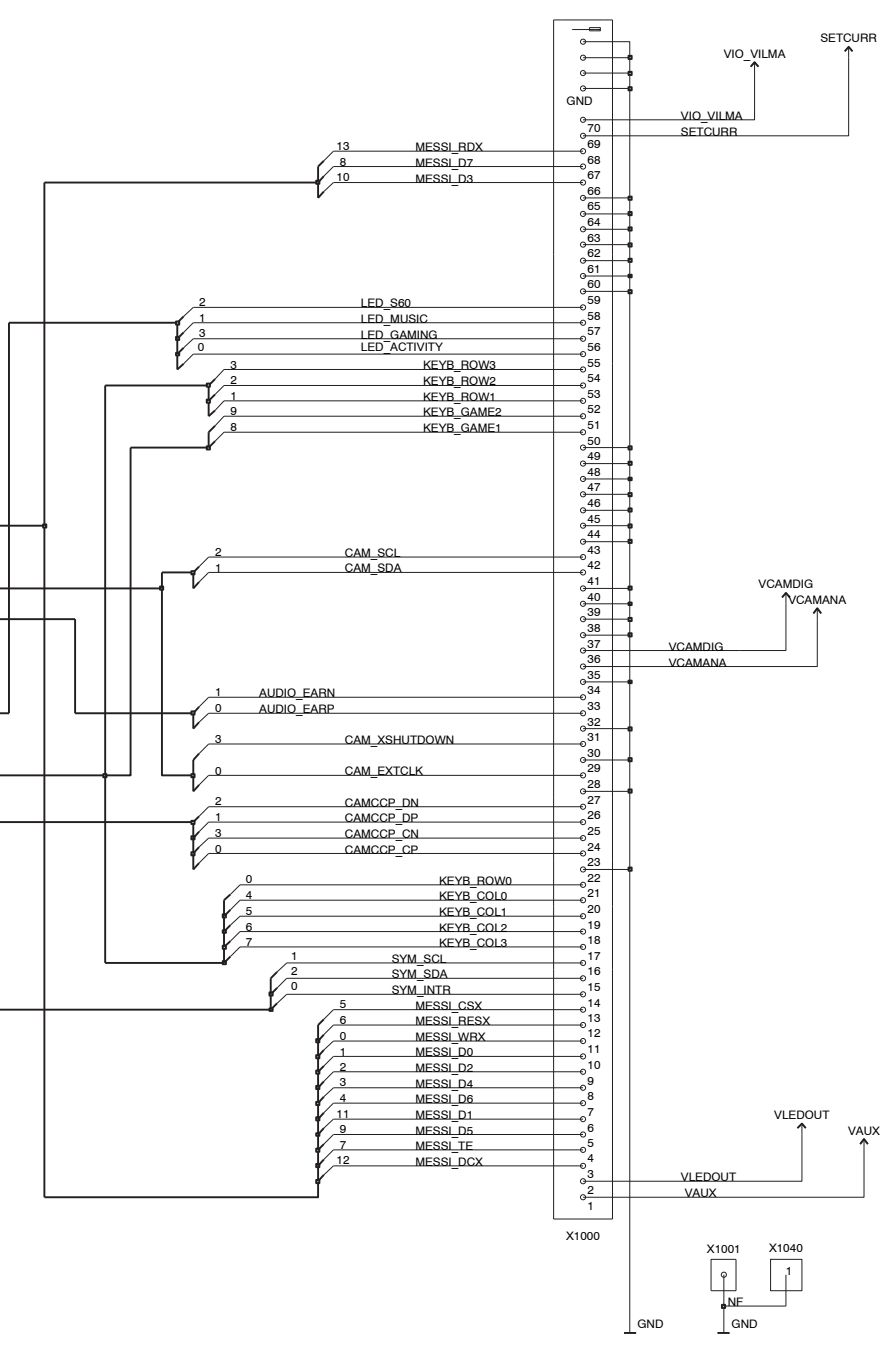
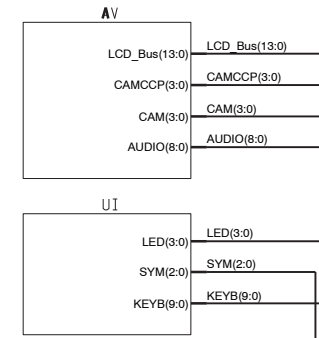
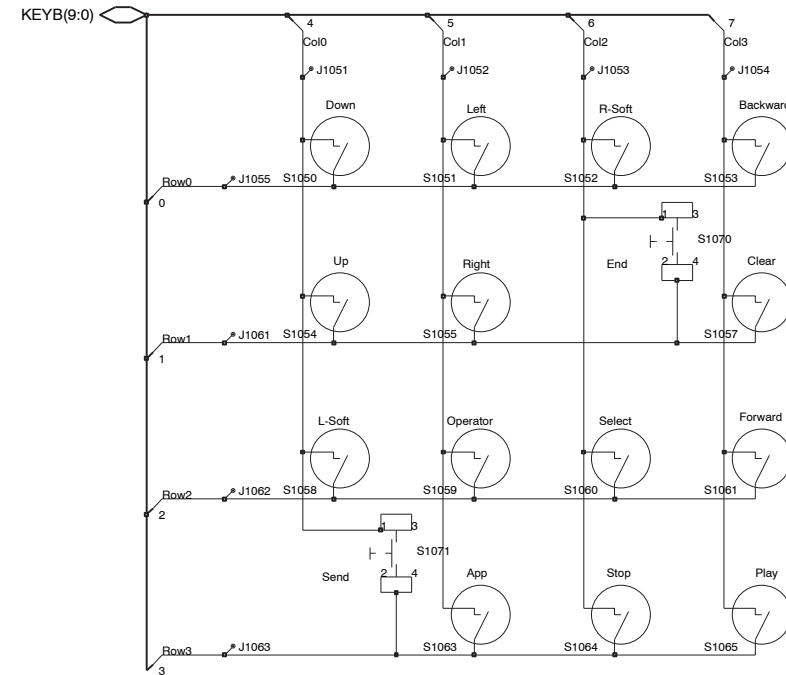
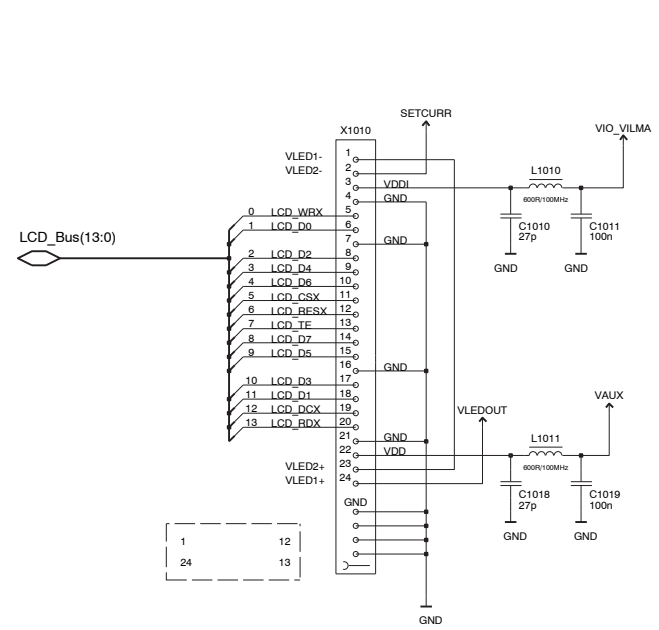

1yz_04
UI_Engine

24
23
22
21
20
19
18
17
16
15
14
13
12
11
10
9
8
7
6
5
4
3
2
1

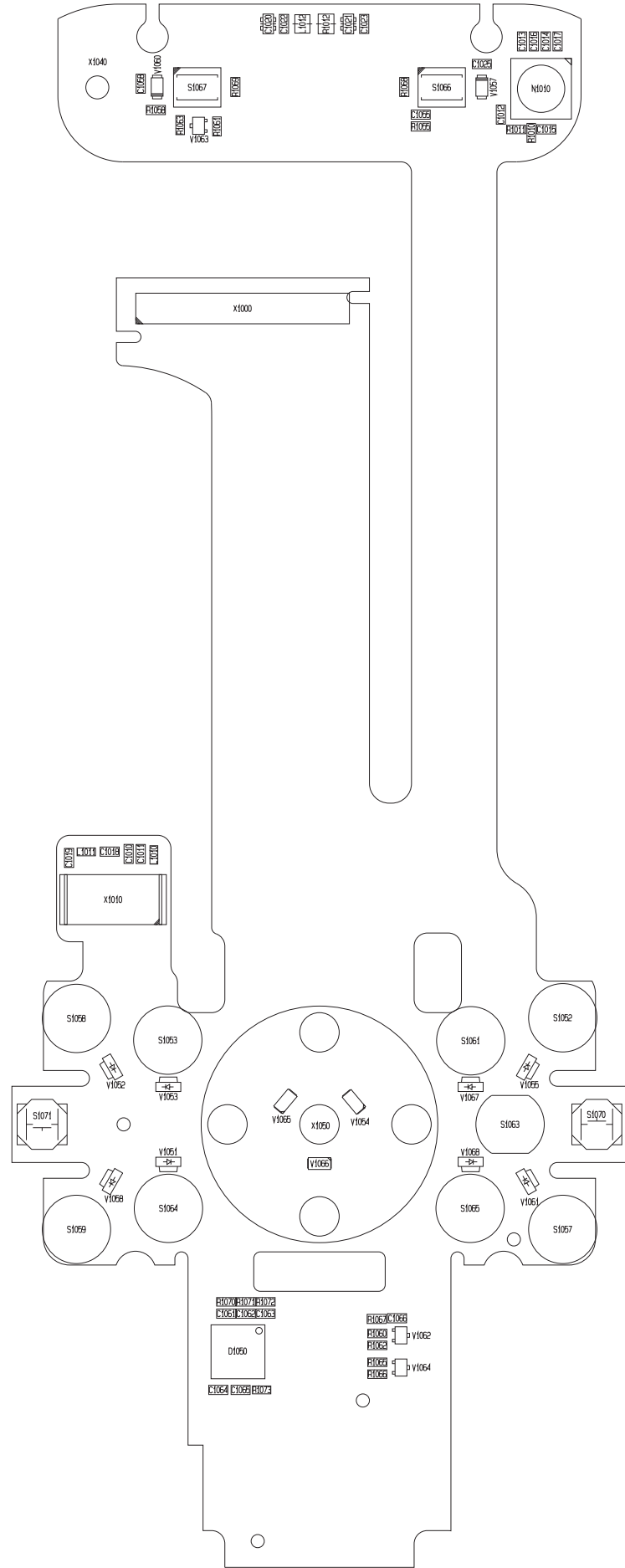

1yz_04a_asmdrw_t.pdf

A | B | C | D | E | F | G | H | I | J | K | L

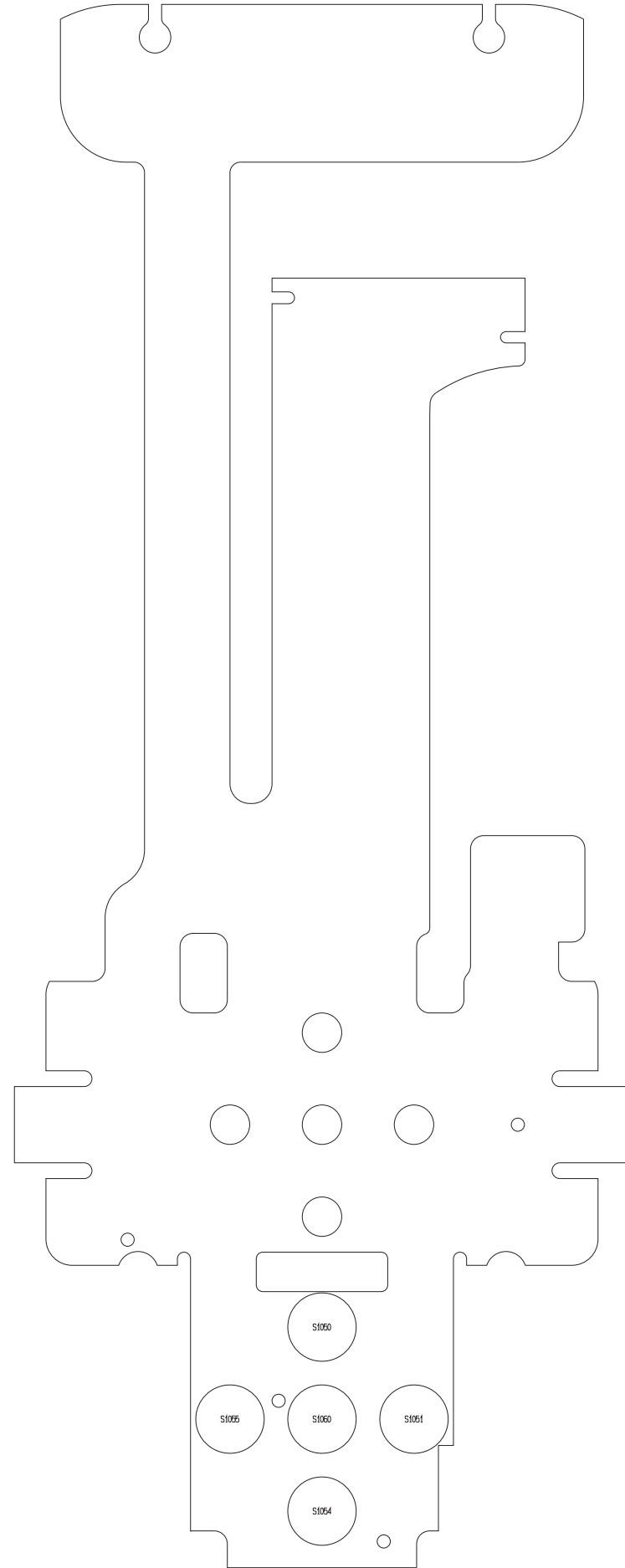

1yz_04a_asmdrw_b.pdf

24
23
22
21
20
19
18
17
16
15
14
13
12
11
10
9
8
7
6
5
4
3
2
1

L | K | J | I | H | G | F | E | D | C | B | A